

# THE ADDITION OF HYDROGEN TO MULTIPLE CARBON-CARBON BONDS

KENNETH N. CAMPBELL AND BARBARA K. CAMPBELL

*Department of Chemistry, University of Notre Dame, Notre Dame, Indiana*

*Received February 18, 1942*

## CONTENTS

I. Introduction.....	77
II. Reduction by chemical methods.....	78
A. Introduction.....	78
B. Theories of chemical reduction.....	78
C. Reduction of olefins.....	82
D. Reduction of acetylenes.....	86
E. Reduction of polyunsaturated hydrocarbons.....	93
1. Reduction of conjugated dienes and polyenes.....	93
2. Reduction of enynes and diynes.....	97
3. Reduction of hydrocarbons containing crossed conjugated systems....	100
4. Reduction of hydrocarbons with cumulated double bonds: allenes....	108
F. The stereochemical course of reduction.....	105
G. Reduction of aromatic hydrocarbons.....	111
1. Reduction of naphthalene.....	112
2. Reduction of anthracene.....	119
3. Reduction of phenanthrene.....	120
4. Reduction of benzene and its derivatives.....	122
H. Reduction of $\alpha$ , $\beta$ -unsaturated carbonyl compounds.....	124
I. Reduction of polyene acids, aldehydes, and ketones.....	127
III. Electrolytic reduction.....	129
A. Introduction.....	129
B. Reduction of unsaturated hydrocarbons.....	134
C. Reduction of unsaturated acids, aldehydes, and ketones.....	135
IV. Catalytic hydrogenation.....	137
A. Introduction.....	137
B. Hydrogenation of olefins.....	138
C. Selective hydrogenation.....	143
D. Hydrogenation of acetylenes, and the stereochemical course of hydrogenation.....	145
E. Hydrogenation of conjugated systems.....	151
F. Hydrogenation of aromatic hydrocarbons.....	156
1. Hydrogenation of benzene and its derivatives.....	156
2. Hydrogenation of naphthalene.....	162
3. Hydrogenation of anthracene.....	164
4. Hydrogenation of phenanthrene.....	166
5. Hydrogenation of fluorene and indene.....	167

## I. INTRODUCTION

The methods used for the reduction of multiple carbon-carbon bonds may be divided into three large groups: chemical, electrolytic, and catalytic. Since the nature and location of the unsaturation determine to a large extent the course of the reduction, the discussion of each class of reducing agent has been further subdivided according to the type of compound studied.

The object of this review has been to collect and correlate the data available on the use of the three methods, and to show the usefulness and limitations of each method. An especial effort has been made to include a complete survey of chemical and electrolytic methods; since, however, there are many excellent reviews on catalytic hydrogenation, only those references which seemed most pertinent have been included.<sup>1</sup>

## II. CHEMICAL REDUCTION

### A. Introduction

The reducing agents in the chemical group include all the dissolving metal combinations, such as sodium in alcohol, sodium amalgam, sodium in liquid ammonia, zinc and tin in neutral, acid, or basic media, zinc amalgam, aluminum amalgam, etc., as well as the soluble metal salts which are reducing agents, such as vanadous, chromous, and titanous chlorides. As a matter of fact, however, most of the work has been done with the alkali metals and with aluminum amalgam.

The chemical reduction of multiple carbon-carbon bonds has been studied, in the course of the last half-century, by a large number of investigators. Out of the welter of results, which are not always concordant, a few definite generalizations emerge. Simple, purely aliphatic olefins, such as amylene (184), are not reduced by dissolving metals or other chemical reducing agents. The presence of an aryl, carbonyl, or ethylene group conjugated with (or in some cases cumulated with) the unsaturation is essential for reduction to occur, although the presence of such conjugation does not make it certain that reduction will take place with all of the reducing agents included in this group. This necessity of conjugation for the chemical reduction of an ethylenic group to occur is in sharp contrast to the results of catalytic hydrogenation, where the simple ethylene bond is reduced more easily than the conjugated one.

Simple acetylenes, unlike olefins, are reduced by some chemical reducing agents, especially by sodium in liquid ammonia, and since the olefins obtained are not further attacked under these conditions, this reaction is a useful one for the preparation of pure olefins (56). Simple aromatic hydrocarbons of the benzene series are in general not reducible by the agents considered in this group, but polynuclear hydrocarbons are.

### B. Theories of chemical reduction

Any mechanism proposed to explain the chemical reduction of unsaturated carbon-carbon linkages must satisfy several conditions. It must account for the dimolecular products sometimes encountered, for the mixture of 1,4- and 1,2-dihydro products obtained from conjugated dienes, for the *trans* reduction of acetylenes, and, of course, for the influence of activating groups. Several theories, fulfilling most of these requirements, have been proposed; they differ chiefly in attributing the reduction to the addition of 'nascent' hydrogen atoms (or sodium atoms) or to the addition of electrons and positive ions.

<sup>1</sup> The literature has been surveyed in Chemical Abstracts to January 1, 1942.



can not add sodium or other alkali metals, can not be reduced by dissolving metal combinations, while those that readily add sodium, such as styrene, stilbene, tetraphenylethylene, etc., are reducible by dissolving metals. Furthermore, Wooster and Smith (340) have shown that alkali-organic compounds are intermediates in the reduction of many substances, such as naphthalene, by sodium in liquid ammonia.

Kuhn and Hoffer (175) have proposed a theory very similar to Willstätter's, to explain the reduction of diene acids by dissolving metals. They consider that the reaction consists in the stepwise addition of sodium atoms (or hydrogen atoms) to the unsaturated group, the first addition being to the carbon atom adjacent to the most negative substituent. The monosodium or monohydro compound thus formed can add a second atom, or it can tautomerize and then complete the addition. The relative amounts of the two products will depend on the relative stabilities of the two intermediate radicals:

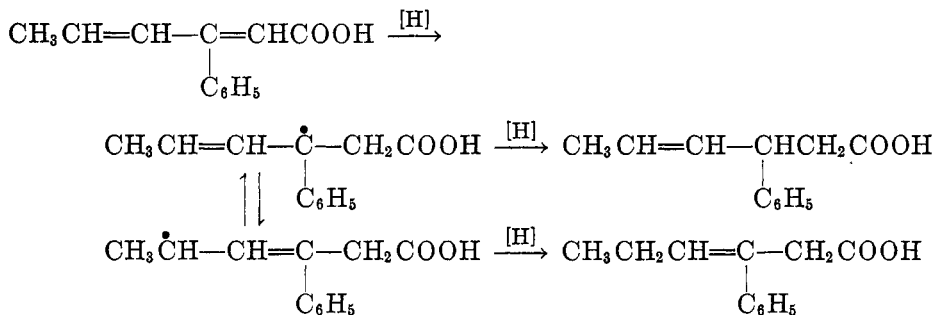

Against Willstätter's theory as a general explanation, several objections have been raised. Hückel (130) has pointed out that it is reasonable to assume that the mechanism of reduction by dissolving metals is the same for all the metals used—sodium, aluminum, zinc, calcium, etc.—and that it seems unlikely that a polyvalent atom such as calcium could add to the 1,4-positions of naphthalene, for example, yet naphthalene is reduced to the 1,4-dihydro derivative by both sodium and calcium in liquid ammonia. Hückel has further emphasized the fact that organo-alkali compounds, such as disodium naphthalene and calcium naphthalene, do not have a covalent bond between the metal and the carbon atom, but are in reality salts; hence in the formation of these substances from the metal and the hydrocarbon, only electrons need to be transferred from the former to the latter. Wilson (332) and Isaacs and Wilson (143, 144, 145) have shown that the electrolytic reduction of conjugated acids such as sorbic acid by high-overvoltage electrodes (mercury, lead) seems to take the same course as does reduction by sodium and sodium amalgam, and may well proceed by the same mechanism, in which case, of course, it cannot involve addition of metal atoms to the double bond.

Several investigators have proposed an ionic mechanism to account for reduction by chemical reducing agents. Conant and his students (63, 65) sug-



*C. Reduction of olefins*

Simple aliphatic olefins are not reduced by alkali metals in alcohol or liquid ammonia; neither do they add these metals in inert media. Lebeau and Picon (184) could obtain no evidence of reduction of pinene, cyclohexene, terpinene, etc., when these hydrocarbons were treated with sodium in liquid ammonia. The presence of an aryl, carbonyl, or second ethylene group conjugated to the double bond is essential for reduction to occur.

The presence of one aryl group adjacent to an ethylenic bond activates it sufficiently to permit reduction by alkali metals in many cases. These reductions may be carried out by three more or less general methods: (a) The olefin may be treated with an alkali metal in an inert medium such as ether, followed by hydrolysis of the organo-alkali compound. (b) A solution of sodium in liquid ammonia may be used, followed by hydrolysis. (c) Sodium or sodium amalgam may be used in alcoholic or aqueous media. These methods do not always give the same results with a given olefin. Of the three, sodium in liquid ammonia would appear to be the strongest reducing agent, and sodium amalgam the weakest.

In connection with method (a)—the addition of alkali metals to arylolefins in inert media—the work of Ziegler (361, 362, 365) and of Schlenk and Bergmann (264 to 268) assumes first place. This work has been thoroughly reviewed in recent articles by Wooster (337) and Ziegler (361), and will not be discussed here in detail.

Ziegler and Schlenk and Bergmann have shown that alkali metals, especially sodium and lithium, add to arylolefins of the types

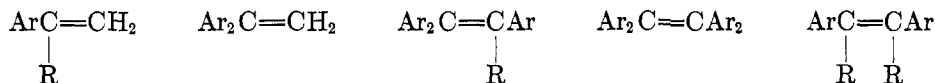

where R is an alkyl group or hydrogen. Lithium frequently adds more readily than does sodium (361), although Gilman (111) found that tetraphenylethylene does not add lithium but does add sodium. Sometimes sodium-potassium alloy gives more rapid addition than does sodium alone (334, 362). Additions which take place but slowly, if at all, in ether, may go more readily in dioxane, or in ether which has been treated with phosphorus pentoxide (178), or in ethylene glycol dimethyl ether (146, 278, 340a).

Alkali metals do not usually add to olefins containing one purely aliphatic-substituted carbon atom (264, 265, 266), such as:



Conant and Blatt (64), however, were able to obtain addition products from dimethylstyrene,  $\text{C}_6\text{H}_5\text{CH}=\text{C}(\text{CH}_3)_2$ , and 1-phenyl-1-pentene,  $\text{C}_6\text{H}_5\text{CH}=\text{CHC}_3\text{H}_7$ , with sodium-potassium alloy; and Ziegler and his students were able to add this alkali to dimethyldiphenylethylene ( $\text{C}_6\text{H}_5)_2\text{C}=\text{C}(\text{CH}_3)_2$  (362).

The reaction of alkali metals with arylolefins is not always one of simple addition. While stilbene adds sodium smoothly, and hydrolysis of the sodium com-



A second abnormal reaction that may occur when an arylolefin is treated with alkali metals in inert solvents is disproportionation, although this does not happen frequently. It has been reported for 1,1-diphenyl-2,2-dimethylethylene (362). This olefin does not add sodium or lithium (266), but with sodium-potassium alloy it undergoes the following reaction:

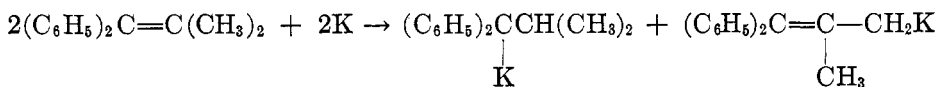

A similar disproportionation has been reported for 1,1-diphenyl-2-benzylethylene (268).

A third abnormal reaction that may occur has been demonstrated by Wittig and Leo (335), and consists of cleavage of an ethane linkage by the alkali metal. This occurred when 1,1,4,4-tetraphenyl-1-butene was treated with potassium, and 1,1,6,6-tetraphenyl-1,5-hexadiene with sodium.

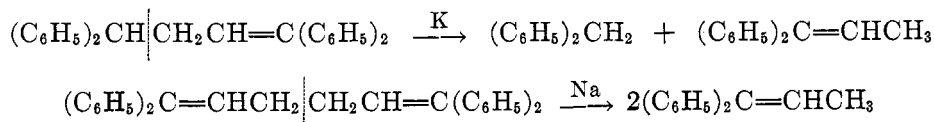

Some of the more sensitive olefins, especially styrene and the aliphatic dienes, are so readily polymerized by alkali metals that the yield of monomeric dihydro compounds is very small when the ordinary procedures are used. This polymerization may be avoided by using an auxiliary substance, such as indene, triphenylmethane, or *N*-ethylaniline, which reacts with the organo-alkali compound as rapidly as it is formed (364, 365).

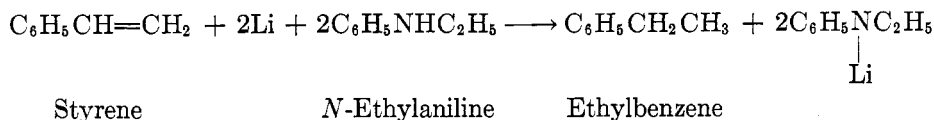

The dilithium addition product is probably an intermediate in this reaction, since lithium and ethylaniline do not react with each other under the conditions used.

Lebeau and Picon (184) and Schlubach (269) were among the first to show that arylolefins could be reduced by sodium in liquid ammonia. In recent years this reaction has been studied in considerable detail by Wooster and his co-workers (339) and by Ziegler and his associates (362, 365). Usually the dihydro product is obtained on hydrolysis, but dimerization may occur here as well as with alkali metals in inert media. Ziegler (362) has shown that this dimerization can be avoided by changing the experimental conditions. For example, 1,1-diphenylethylene forms the dimeric compound when sodium is added to a liquid ammonia solution of the olefin, but when the process is reversed, and the olefin is added to an excess of sodium in liquid ammonia, the main product is diphenylethane.

Some olefins that do not add alkali metals in inert solvents are reduced by



sodium in liquid ammonia. Such an olefin is 1,1-diphenyl-2-methylethylene, which, according to Schlenk and Bergmann (265, 266), is not attacked by sodium in ether, but is readily reduced to 1,1-diphenylpropane by sodium in liquid ammonia (339).

In the reduction of arylolefins by alkali metals in liquid ammonia, the metal salt is undoubtedly an intermediate, for it is possible, in some cases at least, to replace at least one of the metal atoms by an alkyl group on treatment with benzyl chloride or ethyl bromide (339). The organo-alkali compounds are, however, frequently extensively ammonolyzed, even at low temperatures (339). In general, the groups  $\text{RCHNa-}$  and  $\text{ArCHNa-}$  are more readily ammonolyzed than  $\text{Ar}_2\text{CNa-}$ .

Klages and his coworkers (165 to 168) made an extensive study of the reduction of arylolefins by sodium in alcohol. In general, the olefins which readily add alkali metals in inert media are readily reduced by sodium in alcohol, which speaks for a common mechanism for the two reactions. The parallel is not, however, exact, for 1-phenyl-2,2-dimethylethylene reacts with sodium-potassium alloy in ether (64), but it is not reduced by sodium in alcohol (168a).

Very little work appears to have been done with arylolefins and sodium amalgam, but this is certainly a weaker reducing agent than the ones mentioned above, for it is reported that styrene is not reduced by it (291).

Kazanskii and his students have recently developed a new reducing agent, calcium ammonia,  $\text{Ca}(\text{NH}_3)_6$ , made by passing ammonia vapor over metallic calcium (156). This reducing agent will not attack purely aliphatic olefins such as cyclohexene, but it does reduce arylolefins. The reaction proceeds farther than do reactions with sodium in liquid ammonia, and the aromatic nucleus as well as the side chain is attacked. Styrene is reduced by it to 1-ethylcyclohexene. Allylbenzene, which is not reduced by sodium in alcohol, is reduced by calcium ammonia, to propylcyclohexene. Possibly a rearrangement to propenylbenzene precedes the reduction.

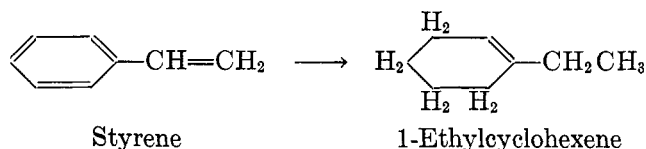

The double bond in the cyclohexene formed in these reductions is always, apparently, on the carbon atom carrying the alkyl side chain.

While the presence of an adjacent aryl group activates an ethylene group sufficiently to permit of reduction by alkali metals, it does not activate it enough for reduction with soluble reducing salts to occur. Karrer, Yen, and Reichstein (150) have shown that while bixin and crocetin can be reduced to the dihydro derivatives with titanium trichloride in ammoniacal solution, this reagent is without effect on styrene, 1,1-diphenylethylene, and toluene. Aluminum amalgam likewise is without action on these compounds (291).

Practically no work has been reported on the reduction of olefins by metals

other than the alkali metals or the alkaline earths. In older work it has been claimed that allyl alcohol can be reduced to propyl alcohol by zinc and sulfuric acid (196) and by aluminum and potassium hydroxide (289), but this has not been confirmed by recent workers. The zinc-copper couple apparently does not bring about reduction of stilbene, for Straus (291) found that the reduction of tolane by this reagent stopped at the stilbene stage. Oleic acid, and other unsaturated acids wherein the double bond is removed from the carboxyl group, can be reduced to the saturated acids by treatment with zinc and acid in the presence of palladium or platinum black (108), but this is probably a case of catalytic hydrogenation.

Some very interesting observations have been made recently by Fuson and his coworkers (10, 11), who have found that 1,2-diaryl-acetylenes and -ethylenes can be reduced at room temperature by benzene and aluminum chloride, forming the diphenylethanes. The mechanism of the reactions is obscure, but it is cer-

TABLE 1  
*Reduction of arylolefins by benzene and aluminum chloride*

COMPOUND REDUCED	PRODUCT
$(p\text{-ClC}_6\text{H}_4)_2\text{C}=\text{CHCOC}_6\text{H}_5$ .....	$(\text{C}_6\text{H}_5)_2\text{CHCH}_2\text{COC}_6\text{H}_5$
$(p\text{-ClC}_6\text{H}_4)(\text{C}_6\text{H}_5)\text{C}=\text{CHCOOH}$ .....	$(\text{C}_6\text{H}_5)_2\text{CHCH}_2\text{COOH}$
$(\text{C}_6\text{H}_5)_2\text{C}=\text{CHCOC}_6\text{H}_5$ .....	$(\text{C}_6\text{H}_5)_2\text{CHCH}_2\text{COC}_6\text{H}_5$
$p\text{-BrC}_6\text{H}_4\text{CH}=\text{CHC}_6\text{H}_5$ .....	$\text{C}_6\text{H}_5\text{CH}_2\text{CH}_2\text{C}_6\text{H}_5$
$(\text{C}_6\text{H}_5)_2\text{C}=\text{CHC}_6\text{H}_5$ .....	$\text{C}_6\text{H}_5\text{CH}_2\text{CH}_2\text{C}_6\text{H}_5$
$\text{C}_6\text{H}_5\text{CH}=\text{CHC}_6\text{H}_5$ .....	$\text{C}_6\text{H}_5\text{CH}_2\text{CH}_2\text{C}_6\text{H}_5$
$p\text{-ClC}_6\text{H}_4\text{CH}=\text{CHC}_6\text{H}_4\text{Cl}$ .....	$\text{C}_6\text{H}_5\text{CH}_2\text{CH}_2\text{C}_6\text{H}_5$
$\text{C}_6\text{H}_5\text{C}\equiv\text{CC}_6\text{H}_5$ .....	$\text{C}_6\text{H}_5\text{CH}_2\text{CH}_2\text{C}_6\text{H}_5$

tainly not merely addition of hydrogen, for substituted aryl groups are replaced by phenyl, and triphenylethylene is converted to dibenzyl. A similar reaction has been reported by Pummerer (251), in which biphenylenediphenylethylene is reduced to the ethane by benzene and aluminum chloride. A summary of Fuson's results is given in table 1.

The most important data on the reduction of olefinic hydrocarbons by chemical reducing agents are summarized in table 2.

#### *D. Reduction of acetylenes*

In contrast to simple olefins, acetylenes without aryl or carbonyl groups conjugated to the triple bond can be reduced by chemical reducing agents.

The addition of alkali metals to acetylenes in inert media has not been studied extensively. A German patent to the Bayer Company (28) reports the conversion of dimethylethynylcarbinol to the olefinic alcohol by treatment with sodium in ether, followed by hydrolysis. The yields are reported to be excellent. In contrast to this, Sung Wooseng (293) was able to obtain little if

TABLE 2  
Reduction of olefins by chemical reducing agents

COMPOUND REDUCED	REAGENTS AND CONDITIONS	PRODUCTS	REFERENCES
$C_6H_5CH=CH_2$ .....	Na, ether, hydrolysis	Polymers	(264)
	Na (Li), ether, ethylaniline present	$C_6H_5CH_2CH_3$	(364)
	Na, liquid $NH_3$	$C_6H_5CH_2CH_3$ and polymers	(185a, 339, 102)
	Na amalgam, alcohol	No reduction	(291)
$C_6H_5CH_2CH=CH_2$ .....	Na, alcohol	$C_6H_5CH_2CH_3$	(168a)
	$Ca(NH_3)_6$	1-Ethylcyclohexene	(156)
$(CH_3)_3C_6H_2CH=CHCH_3$ .....	$TiCl_3, NH_4OH$	No reduction	(150)
$C_6H_5CH_2CH=CH_2$ .....	$Ca(NH_3)_6$	1-Propylcyclohexene	(156)
$C_6H_5CH=CHCH_3$ .....	Na, alcohol	$C_6H_5CH_2CH_2CH_3$	(168a)
$(CH_3)_3C_6H_2CH=CHCH_3$ .....	Na, alcohol	No reduction	(167a)
$C_6H_5CH=CHC_2H_5$ .....	Na, alcohol	$C_6H_5(CH_2)_3CH_3$	(167b)
$C_6H_5CH=CHC_3H_7$ .....	Na-K, ether	$C_6H_5CH_2CH_2C_3H_7$	(64)
$C_6H_5CH=CHCH(CH_3)C_2H_5$ ...	Na, alcohol	$C_6H_5CH_2CH_2C_3H_7$	(168b)
	Na-K, ether	$C_6H_5CH_2C(CH_3)_2$	(64)
$C_6H_5CH=C(CH_3)_2$ .....	Na (Li), ether	$C_6H_5CH_2C(CH_3)_2$	(265)
	Na, alcohol	No reaction	(165a)
$C_6H_5CH=C(C_2H_5)_2$ .....	Na, alcohol	No reduction	(168a)
$C_6H_5C=CH_2$ .....	Na, alcohol	$C_6H_5CH(CH_3)_2$	(165a)
$C_6H_5C(CH_3)=CHCH_3$ .....	Na, alcohol	$C_6H_5CHC_2H_5$	(165a)
$C_6H_5C(CH_3)=CHC_2H_5$ .....	Na, alcohol	$C_6H_5CHC_3H_7(n)$	(165d)
$C_6H_5C(CH_3)=CHC_3H_7(i)$ .....	Na, alcohol	$C_6H_5CHC_4H_9(i)$	(168b)
$C_6H_5C(CH_3)=CHC_4H_9(i)$ .....	Na, alcohol	$C_6H_5CHC_5H_{11}(i)$	(165a)
$C_6H_5C(CH_3)=CHCH_3$ .....	Na, alcohol	$C_6H_5CHCH_2CH_3$	(168a)
$C_6H_5C(CH_3)=C(CH_3)_2$ .....	Na (Li) ether	No reaction	(265)

TABLE 2—Continued

COMPOUND REDUCED	REAGENTS AND CONDITIONS	PRODUCTS	REFERENCES
$C_6H_5C=C(CH_3)_2$ .....	Na, alcohol	No reduction	(168a)
$\begin{array}{c} C_2H_5 \\   \\ C_6H_5C=C(CH_3)_2 \end{array}$ .....	Na, alcohol	No reduction	(168a)
$\begin{array}{c} C_6H_7 \\   \\ C_6H_5CH=CHC_6H_5 \end{array}$ .....	Na (Li), ether	$C_6H_5CH_2CH_2C_6H_5$	(264, 340a)
$\begin{array}{c} C_6H_5C=CHC_6H_5 \\   \\ CH_3 \end{array}$ .....	Na, liquid NH <sub>3</sub> Na, alcohol Na, ether	$C_6H_5CH_2CH_2C_6H_5$ $C_6H_5CH_2CH_2C_6H_5$ $C_6H_5CHCH_2C_6H_5$	(102) (165b) (267)
$\begin{array}{c} C_6H_5C=CHC_6H_5 \\   \\ CH_3 \end{array}$ .....	Na, alcohol	$\begin{array}{c} CH_3 \\   \\ C_6H_5CHCH_2C_6H_5 \end{array}$	(165b)
$\begin{array}{c} C_6H_5C=CHC_6H_5 \\   \\ CH_3 \end{array}$ .....	Na, alcohol	$\begin{array}{c} CH_3 \\   \\ C_6H_5CHCH_2C_6H_5 \end{array}$	(167b)
$\begin{array}{c} C_2H_5 \\   \\ p-CH_3C_6H_4CH=CHC_6H_4CH_3 \\   \\ C_6H_5C=CC_6H_5 \end{array}$ .....	H <sub>2</sub> S and heat Na, ether	Di- <i>p</i> -tolylethane $C_6H_5CHCHC_6H_5$	(17) (227, 265)
$\begin{array}{c} H_3C \quad CH_3 \\   \quad   \\ C_6H_5C=CHC_6H_5 \end{array}$ .....	Na, alcohol	$\begin{array}{c} H_3C \quad CH_3 \\   \quad   \\ C_6H_5CHCHC_6H_5 \end{array}$	(227)
$\begin{array}{c} C_6H_5C=CHC_6H_5 \\   \\ CH_2C_6H_5 \end{array}$ .....	Na, alcohol	$\begin{array}{c} H_3C \quad CH_3 \\   \quad   \\ C_6H_5CHCH_2C_6H_5 \end{array}$	(168a)
$(C_6H_5)_2C=CH_2$ .....	Na, ether	$\begin{array}{c} CH_2C_6H_5 \\   \\ (C_6H_5)_2CHCH_2 \end{array}$	(337)
$(C_6H_5)_2C=CH_2$ .....	Na, liquid NH <sub>3</sub> , excess sodium	$\begin{array}{c} (C_6H_5)_2CHCH_2 \\   \\ (C_6H_5)_2CHCH_3 \end{array}$	(362)
$(C_6H_5)_2C=CH_2$ .....	Na, liquid NH <sub>3</sub> , excess olefin	$(C_6H_5)_2CHCH_2$	(362)
$(C_6H_5)_2C=CH_2$ .....	Na, alcohol	$\begin{array}{c} (C_6H_5)_2CHCH_2 \\   \\ (C_6H_5)_2CHCH_3 \end{array}$	(165b)
$(C_6H_5C_6H_4)_2C=CH_2$ .....	Na, ether	$\begin{array}{c} (C_6H_5C_6H_4)_2CHCH_2 \end{array}$	(265)
$(C_6H_5)_2C=CHCH_3$ .....	Na (Li), ether	No reaction	(265)
$(C_6H_5)_2C=CHCH_3$ .....	Na, K, liquid NH <sub>3</sub>	$(C_6H_5)_2CHCH_2CH_3$	(339)
$(C_6H_5)_2C=CHCH_3$ .....	Na, alcohol	$(C_6H_5)_2CHCH_2CH_3$	(165b)
$(C_6H_5)_2C=CHC_2H_5$ .....	Na, ether	No reaction	(266)
$(C_6H_5)_2C=CHC_2H_5$ .....	Na, alcohol	Difficult to reduce; obtain $(C_6H_5)_2CHCH_2C_2H_5$	(167b)

TABLE 2—Concluded

COMPOUND REDUCED	REAGENTS AND CONDITIONS	PRODUCTS	REF-ERENCES
$(C_6H_5)_2C=CHC_6H_{11}(n)$ .....	Na, alcohol	$(C_6H_5)_2CHC_6H_{11}(n)$	(167b)
$(C_6H_5)_2C=C(CH_3)_2$ .....	Na (Li), ether K, ether	No addition Disproportionation	(265) (362)
$(C_6H_5)_2C=CHCH_2C_6H_5$ .....	Li, ether Na, liquid $NH_3$ , low tempera- ture	Disproportionation $(C_6H_5)_2CHCH_2CH_2C_6H_5$	(268) (362)
$(C_6H_5)_2C=C(CH_2C_6H_5)_2$ .....	Na (Li), ether	No addition	(266)
$(C_6H_5)_2C=CHCH(C_6H_5)_2$ .....	Na (Li), ether Na, liquid $NH_3$	Complex reaction $(C_6H_5)_2CHCH_2CH(C_6H_5)_2$	(265) (339)
$(C_6H_5)_2C=CHC(C_6H_5)_3$ .....	Na, butyl alcohol Li, ether	$(C_6H_5)_2CHCH_2C(C_6H_5)_3$ $(C_6H_5)_3CH$ and $(C_6H_5)_2$ - $CHCH=CHCH(C_6H_5)_2$	(169) (169)
$(C_6H_5)_2C=CHC_6H_5$ .....	Na (Li), ether Na (K), liquid $NH_3$	$(C_6H_5)_2CHCH_2C_6H_5$ $(C_6H_5)_2CHCH_2C_6H_5$	(265) (339)
$(C_6H_5)_2C=CC_6H_5$ .....	Na, ether	$(C_6H_5)_2CHCHC_6H_5$	(265)
$(C_6H_5)_2C=C(C_6H_5)_2$ .....	Na, ether Li, K, ether Na, liquid $NH_3$ Al amalgam	$(C_6H_5)_2CHCH(C_6H_5)_2$ No addition $(C_6H_5)_2CHCH(C_6H_5)_2$ No reduction	(265) (111) (339) (298)

any reduction of various carbinols of the formula

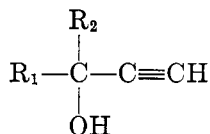

by treatment with sodium in ether. Tolane reacts very slowly with sodium in ether, and the product is chiefly a mixture of polymers (265), but it reacts with lithium in ether more readily. Bergmann (31, 33) isolated triphenylnaphthalene from the reaction mixture after hydrolysis, but Smith and Hoehn (288) have recently shown that the primary product is tetraphenylbutadiene, which must result from a dimeric addition of lithium similar to that obtained in the case of 1,1-diphenylethylene. In the presence of excess lithium the tetraphenylbutadiene is converted to triphenylnaphthalene:

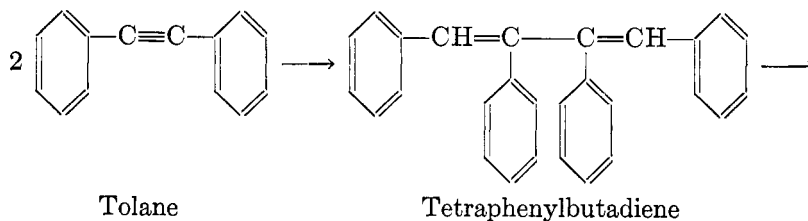

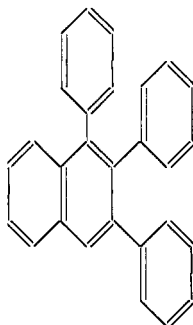

Triphenylnaphthalene

Sodium in liquid ammonia was early observed to cause reduction of acetylene and its alkyl derivatives. Moissan (215, 216), in a study of the preparation of alkali acetylides, found that acetylene reacted with sodium, potassium, cesium, and rubidium in liquid ammonia in accordance with the following equation:



A similar observation was made by Lebeau and Picon (185) for monoalkylacetylenes. They found that these hydrocarbons reacted with sodium in liquid ammonia to give 2 moles of the sodium alkylacetylide and 1 mole of olefin, and for this reason they advocated the use of sodium amide for preparing the acetylide salts of alkylacetylenes. Phenylacetylene on treatment with sodium in liquid ammonia yields, not styrene, but ethylbenzene (185a). Recent work by Campbell and Eby (56, 57) has shown that both mono- and di-alkylacetylenes can be reduced to the corresponding olefins, in excellent yields, by sodium in liquid ammonia, and that this is one of the best means of preparing olefins of known position of the double bond, for the olefin is not contaminated by any saturated hydrocarbon. The method can also be used with branched-chain acetylenes, such as 3,3-dimethyl-4-nonyne (60), and with acetylenic carbinols (57). In the case of dialkylacetylenes, *trans* olefins are formed. Lithium has been found to give the same results as sodium.

Sodium in alcohol is not as efficient a reducing agent for acetylenes as is sodium in liquid ammonia. It will reduce toluene to stilbene (291), but it is without effect on mono- and di-alkylacetylenes. Bourguel (43) reported that tetramethylbutynediol was reduced by this reagent to the *trans* ethylenic glycol. Subsequent work by Zalkind (348) and by Johnson (147a) has shown this to be incorrect; the product is a polymorphic form of the acetylene glycol, and no reduction takes place. Sodium amalgam has not been much used, but it appears to be too weak, as phenylacetylene is not attacked by it in the cold (291), nor is toluene (16).

Some acetylenes can be reduced by zinc dust, either in acid or basic solution, or by the zinc-copper couple in neutral solution. Dimethylethynylcarbinol is converted to the ethylenic carbinol by zinc and acetic acid or by the zinc-copper couple (28), and acetylene, phenylacetylene, mono- and di-vinylacetylenes, and propiolic acid are said to be reduced to the corresponding olefins by the zinc-copper couple (87, 88), or by zinc in basic solution. Straus (291) found that

TABLE 3  
Reduction of acetylenes by chemical reducing agents

COMPOUND REDUCED	REAGENTS AND CONDITIONS	PRODUCTS	REFERENCES
HC≡CH .....	Na, liquid NH <sub>3</sub> (also K, Cs, Rb) Zn-Cu, H <sub>2</sub> O Cr <sup>++</sup> in acid or NH <sub>4</sub> OH solution	CH <sub>2</sub> =CH <sub>2</sub> and CH≡CNa CH <sub>2</sub> =CH <sub>2</sub> CH <sub>2</sub> =CH <sub>2</sub>	(215, 216) (88) (303)
RC≡CH (where R = normal alkyl up to C <sub>6</sub> )	Na, liquid NH <sub>3</sub> Na or Li, liquid NH <sub>3</sub>	RCH=CH <sub>2</sub>	(185, 57)
RC≡CR' (where R and R' are normal alkyl groups)		RCH=CHR'	(56, 57)
(CH <sub>3</sub> ) <sub>2</sub> CC≡CH   OH	Na, ether Zn, acetic acid Zn-Cu couple	(CH <sub>3</sub> ) <sub>2</sub> CCH=CH <sub>2</sub>   OH	(28) (28) (28, 88)
CH <sub>3</sub>   C <sub>2</sub> H <sub>5</sub> CC≡CH   OH	Na, liquid NH <sub>3</sub>	CH <sub>3</sub>   C <sub>2</sub> H <sub>5</sub> CCH=CH <sub>2</sub>   OH	(57)
R <sub>2</sub>   R <sub>1</sub> CC≡CH   OH	Na, ether Mg amalgam, CH <sub>3</sub> -OH Fe, acetic acid Mg, acetic acid	Little or no reduction	(293)
{ R <sub>1</sub> = CH <sub>3</sub> and R <sub>2</sub> = <i>t</i> -C <sub>4</sub> H <sub>9</sub> R <sub>1</sub> = R <sub>2</sub> = <i>n</i> -C <sub>3</sub> H <sub>7</sub> R <sub>1</sub> = CH <sub>3</sub> and R <sub>2</sub> = <i>i</i> -C <sub>3</sub> H <sub>7</sub>			
CH <sub>3</sub>   HC≡CCCH <sub>2</sub> CH <sub>2</sub> CH=C(CH <sub>3</sub> ) <sub>2</sub>   OH	Na, moist ether	CH <sub>3</sub>   CH <sub>2</sub> =CHCCH <sub>2</sub> CH <sub>2</sub> CH=C(CH <sub>3</sub> ) <sub>2</sub>   OH Linalool	(258a) (258a)
(CH <sub>3</sub> ) <sub>2</sub> CC≡CC <sub>4</sub> H <sub>9</sub> ( <i>n</i> )   OH	Na, liquid NH <sub>3</sub>	(CH <sub>3</sub> ) <sub>2</sub> CCH=CHC <sub>4</sub> H <sub>9</sub>   OH	(57)
(CH <sub>3</sub> ) <sub>2</sub> CC≡CC(CH <sub>3</sub> ) <sub>2</sub>         OH   OH	Na, alcohol	No reduction	(348, 147a)

TABLE 3—Concluded

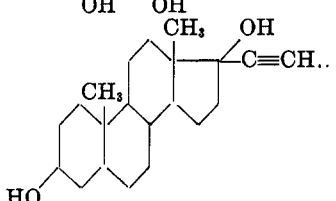
COMPOUND REDUCED	REAGENTS AND CONDITIONS	PRODUCTS	REFERENCES
$C_6H_5C\equiv CH$ .....	Na amalgam, cold	No reduction	(291)
	Zn, acetic acid	$C_6H_5CH=CH_2$	(16)
	Zn-Cu	$C_6H_5CH=CH_2$ and $C_6H_5CH=CHCH=CHC_6H_5$	(291)
	Zn with Cu or Cd	$C_6H_5CH=CH_2$	(88)
	Zn, basic solution	$C_6H_5CH=CH_2$	(87)
$C_6H_5C\equiv CC_6H_5$ .....	Na, ether	Slow reaction; polymers formed	(265)
	Li, ether	$[(C_6H_5)_2C=CH-]_2$ and 1,2,3-triphenylnaphthalene	(31, 265, 288)
	Na, methanol	<i>trans</i> -Stilbene	(16)
	Na, ethanol	$C_6H_5CH_2CH_2C_6H_5$	(16)
	Na amalgam	No reduction	(16)
	Zn, acetic acid	<i>trans</i> -Stilbene	(16)
	Zn-Cu, alcohol	<i>cis</i> -Stilbene	(291)
	$C_6H_5, AlCl_3$	$C_6H_5CH_2CH_2C_6H_5$	(11)
$(C_6H_5)_2CC\equiv CC(C_6H_5)_2$ .....	Na, alcohol	No reduction	(345)
$(C_6H_5)_2CC(OH)C(OH)C_6H_5$ .....	Na, alcohol	No reduction	(345)
	Na, xylene, alcohol	Olefin	(117)

phenylacetylene on treatment with zinc and alcohol formed styrene chiefly, but also a little phenylbutadiene. This may possibly be a dimerizing reduction similar to that found with arylolefins and sodium. Sung Wooseng (293) was unable to reduce tertiary acetylenic carbinols with magnesium amalgam, or with iron or magnesium and acetic acid.

No work appears to have been done on the reduction of acetylenic hydrocarbons by calcium ammonia, but since this reagent will attack a benzene ring, it is probable that it will reduce acetylenes also. The action of soluble metal



salts on acetylenic hydrocarbons has received but little attention. Traube (303) found that acetylene itself could be reduced to ethylene in good yield by chromous chloride in acid or in ammoniacal solution, but Karrer (150) observed that titanium trichloride is not a strong enough reducing agent to attack toluene, although it will bring about the reduction of some conjugated compounds.

The data on the reduction of acetylenes by chemical methods are summarized in table 3. The work on the stereochemical course of reduction of disubstituted acetylenes is discussed in section II F.

### *E. Reduction of polyunsaturated hydrocarbons*

#### 1. Reduction of conjugated dienes and polyenes

In contrast to a simple ethylenic group, a system of two or more such groups united in a conjugated chain is reducible by dissolving metal combinations, and in this respect the conjugated diene hydrocarbons resemble the acetylenes and arylolefins. They are, in fact, more easily reduced, since most of them are attacked by sodium amalgam in the cold, and the polyenes and some of the aryl dienes are reduced by aluminum amalgam, a reagent which is without effect on acetylenes, arylolefins, and purely aliphatic dienes (291, 333).

Alkali metals in inert media cause rapid polymerization of phenylbutadiene and the aliphatic dienes such as butadiene, isoprene, and dimethylbutadiene (361, 364); this reaction was of importance in the early development of synthetic rubber. Ziegler and his coworkers (361) considered that the primary product is an organo-alkali compound, formed by the addition of two atoms of the metal to one molecule of the diene. This organo-alkali compound can then add to unreacted diene, forming a new organo-alkali compound. By repetition of this process, polymers of very high molecular weight can be obtained. The addition occurs in the 1,4-positions, for Midgley and Henne (213) demonstrated that the dimerization of isoprene by potassium led to three dimethyloctadienes, as shown below:

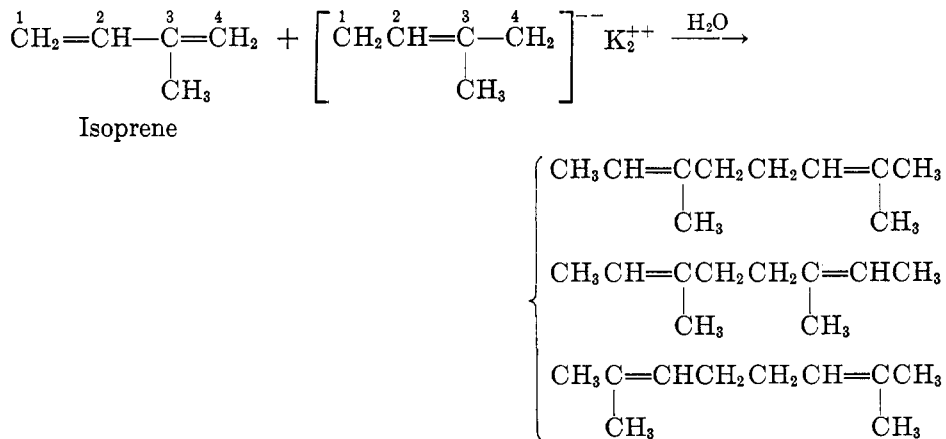



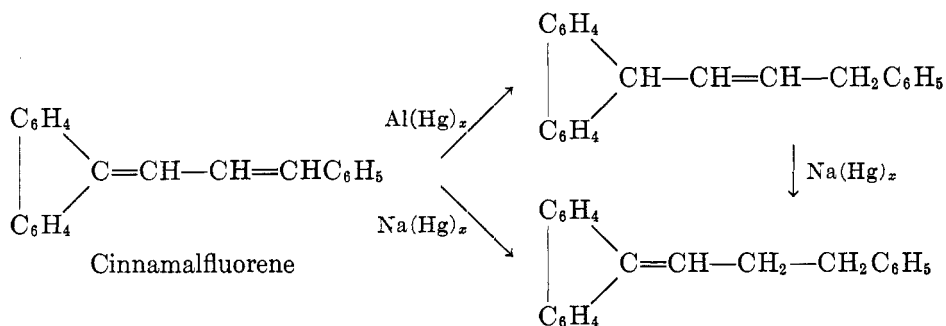

This same hydrocarbon, cinnamalfuorene, adds sodium in ether to form the dimeric addition product (265).

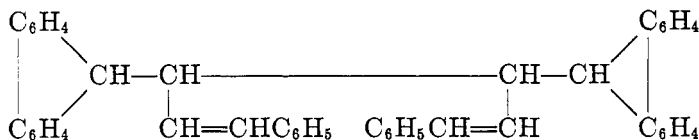

Thiele (299) also obtained some dimer upon the reduction of cinnamalfuorene with aluminum amalgam.

Other symmetrically substituted diaryldienes are reduced in the terminal positions by the reagents mentioned above. 1,1,4,4-Tetraphenylbutadiene adds lithium in the terminal positions (38) and is reduced by sodium amalgam to 1,1,4,4-tetraphenyl-2-butene (265a), but on treatment with sodium in amyl alcohol it is reduced to the tetraphenylbutane (307); this reaction indicates that the terminal dihydro compound is rearranged by the alkali and higher temperature to 1,1,4,4-tetraphenyl-1-butene, which is then further reduced. 1,1,6,6-Tetraphenylhexatriene slowly adds sodium or lithium (potassium more rapidly), and hydrolysis gives 1,1,6,6-tetraphenyl-2,4-hexadiene (334). Allen (12) found that 2,3-diphenylbutadiene is completely reduced by sodium in liquid ammonia, a fact that is not surprising, for the 1,4-reduction product would be dimethylstilbene, which is itself reduced by alkali metals. 1,2,3,4-Tetraphenylbutadiene adds sodium in the 1,4-positions, and is difficultly reduced to the 1,4-dihydro compound by sodium in alcohol, the reaction stopping at this stage (32), although it would be expected that the dihydro compound would be easily reduced further by alkali metals.

Very little work has been reported on the course of the reduction of unsymmetrical aryldienes. It is here, however, that one would expect non-terminal addition to occur most extensively. 1-Phenylbutadiene, according to Klages (165), is reduced terminally by sodium in alcohol, although 1-phenyl-3-methylbutadiene is reported to give a 1,2-dihydro compound. Conclusive proof of these structures is, however, lacking.

With purely aliphatic dienes, such as butadiene, isoprene, and 2,3-dimethylbutadiene, addition of alkali metals (363, 364) and reduction by these metals

in reactive solvents tend to occur exclusively in the 1,4-positions (130, 212, 213); sometimes dimers and polymers are also formed.

Two cases have been reported in which the reduction of an aliphatic polyene does not occur exclusively in the terminal positions. Dupont and his coworkers (77) studied the reduction of alloöcimene in detail, using Raman-spectra data among other evidence to establish the structures of the products. With sodium in liquid ammonia alloöcimene forms a dihydro product which is a homogeneous substance and contains a conjugated system. It has been shown to be 2,6-dimethyl-3,5-octadiene (II), and it is reduced further to 2,6-dimethyl-4-octene (III) by sodium in liquid ammonia.

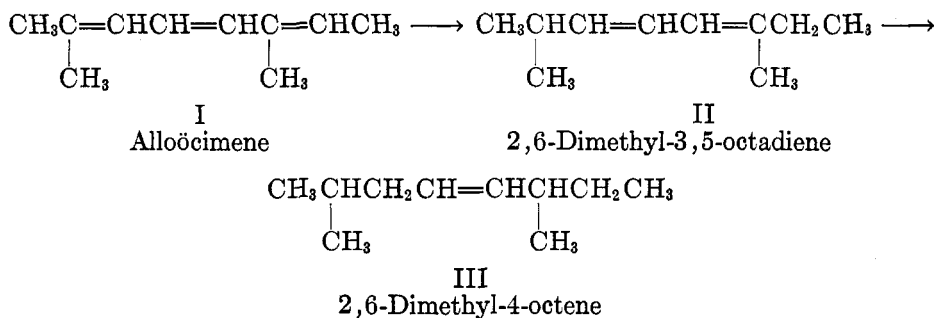

When alloöcimene is reduced by sodium and alcohol, however, the product is not identical with II, and is not homogeneous. From Raman spectra and reduction experiments Dupont and coworkers concluded that it is an approximately equimolar mixture of II and the 3,6-reduction product,

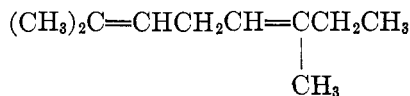

which does not contain a conjugated system.

In a similar fashion, Dupont and Desreux (75, 76) have shown that while reduction of  $\beta$ -myrcene by sodium in alcohol occurs largely in the 1,4-positions, as reported by Semmler (279), it does not do so exclusively, and there is also some 1,2-dihydro product formed.

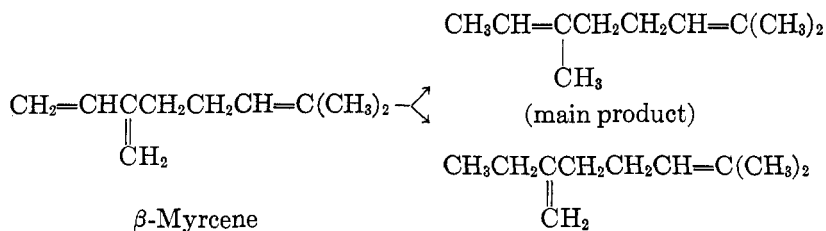

It is possible that a careful reëxamination of the reduction products from other unsymmetrical dienes will reveal additional cases where terminal reduction is not the sole reaction.



TABLE 4  
*Reduction of conjugated diene and polyene hydrocarbons*

COMPOUND REDUCED	REDUCING AGENTS AND CONDITIONS	PRODUCTS	REFER-ENCES
Butadiene..... $\text{CH}_2=\text{CHCH}=\text{CH}_2$	Na, ether Na, ether, ethylaniline Na (Ca), liquid $\text{NH}_3$	Polymers <i>cis</i> -2-Butene 2-Butene and dimer	(364) (363) (130)
Isoprene..... $\text{CH}_2=\text{CHC}(\text{CH}_3)=\text{CH}_2$	Na, ether Na, liquid $\text{NH}_3$ (excess so- dium) K, alcohol	Polymers 2-Methyl-2-butene Dimers; 2,6-, 2,7-, and 3,6-dimethyl- 2,6-octadienes	(364) (212) (213)
Dimethylbutadiene..... $\text{CH}_2=\text{C}(\text{H}_3)\text{C}(\text{CH}_3)=\text{CH}_2$	Na (Li), ether Na (Li), ether, ethylaniline K, alcohol Ca( $\text{NH}_3$ ) <sub>6</sub>	3 per cent tetrame- thylethylene, 60 per cent 2,3,6,7- tetramethyl- 2,6-octadiene Tetramethylethylene 2,3,6,7-Tetrame- thyl-2,6-octa- diene; higher poly- mers	(364) (363) (213) (156)
Piperylene..... $\text{CH}_2=\text{CHCH}=\text{CHCH}_3$	Li, ether Na, ether, tri- phenylme- thane Na, liquid $\text{NH}_3$	Polymers Hexamers and higher polymers 5-Methyl-3-heptene (largely <i>trans</i> )	(364) (364) (77)
5-Methyl-2,4-heptadiene..... $\text{CH}_3\text{CH}=\text{CHCH}(\text{CH}_3)=\text{CCH}_2\text{CH}_3$	Na, alcohol Na, liquid $\text{NH}_3$	2,6-Dimethyl-3,5- octadiene and 2,6- dimethyl-2,5-octa- diene 2,6-Dimethyl-3,5- octadiene	(77) (77)
Alloöcimene..... $(\text{CH}_3)_2\text{C}=\text{CHCH}(\text{CH}_3)=\text{CHCH}_3$	Na, alcohol	Chiefly 3,7-dimethyl- 2,6-octadiene; some 2-ethyl-6- methyl-1,5-hep- tadiene	(75, 76, 279)
$\beta$ -Myrcene..... $\text{CH}_2=\text{CHC}(\text{CH}_2)_2\text{CH}_2\text{CH}=\text{C}(\text{CH}_3)_2$	Na, alcohol	Cyclohexene 4,6-Dimethyl-2-cy- clohexene	(156) (21)
1,3-Cyclohexadiene.....	Ca( $\text{NH}_3$ ) <sub>6</sub>		
4,6-Dimethyl-1,3-cyclohexadiene.....	Na, alcohol		

TABLE 4—Continued

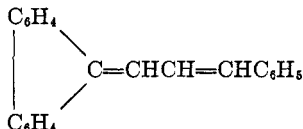
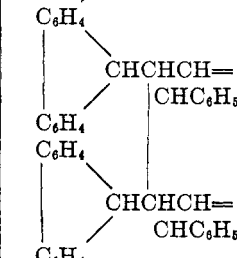
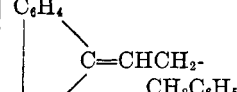
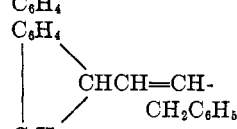
COMPOUND REDUCED	REDUCING AGENTS AND CONDITIONS	PRODUCTS	REFERENCES
Carotenoids.....	Al amalgam	$\alpha,\omega$ -Dihydro compounds	(151, 178)
1-Phenylbutadiene..... $C_6H_5CH=CHCH=CH_2$	Na, alcohol	1-Phenyl-2-butene	(165c)
1-Phenyl-3-methylbutadiene..... $C_6H_5CH=CHC(CH_3)=CH_2$	Na, alcohol	1-Phenyl-3-methyl-3-butene	(165c)
1,4-Diphenylbutadiene..... $C_6H_5CH=CHCH=CHC_6H_5$	Na (Li), ether	<i>cis</i> -1,4-Diphenyl-2-butene	(265a)
	Na amalgam, alcohol	<i>trans</i> -1,4-Diphenyl-2-butene	(291, 265a)
	Al amalgam	No reduction	(298)
	Zn-Cu, alcohol	No reduction	(291)
ArCH=CHCH=CHAr, where Ar is } <i>p</i> -tolyl or <i>p</i> -anisyl }	Na, amyl alcohol	ArCH <sub>2</sub> CH <sub>2</sub> CH <sub>2</sub> CH <sub>2</sub> Ar	(46)
Cinnamalfluorene..... 	Na (Li), ether	Dimer, 	(265)
	Na amalgam		(177)
	Al amalgam		(298, 177)
2,3-Diphenylbutadiene..... $CH_2=C(C_6H_5)-C(C_6H_5)=CH_2$	Na, liquid NH <sub>3</sub>	<i>meso</i> 2,3-Diphenylbutane	(12)
	Na amalgam	No reduction	(12)
1,1,4,4-Tetraphenylbutadiene..... $(C_6H_5)_2C=CHCH=C(C_6H_5)_2$	Na (Li), ether	<i>trans</i> -1,1,4,4-Tetraphenyl-2-butene	(265a)
	Na, amyl alcohol	Tetraphenylbutane	(307)
	Na amalgam, alcohol	<i>trans</i> -1,1,4,4-Tetraphenyl-2-butene	(265a)
1,2,3,4-Tetraphenylbutadiene..... $C_6H_5CH=C(C_6H_5)-C(C_6H_5)=CHC_6H_5$	Na, ether	1,2,3,4-Tetraphenyl-2-butene and an indene derivative	(32)
	Na, amyl alcohol	1,2,3,4-Tetraphenyl-2-butene and an indene derivative	(32)
	Al amalgam	No reduction	(32)





(I), the benzofulvenes (II), and the dibenzofulvenes (III). Practically all of these are capable of reacting with sodium in inert media (39, 265).

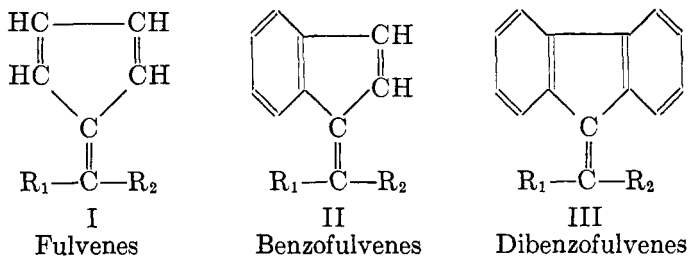
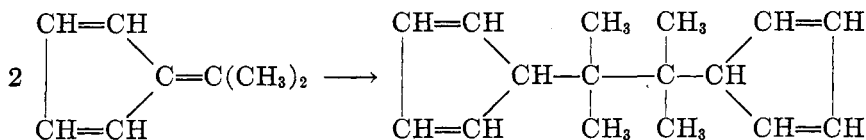

TABLE 5

*Chemical reduction of enynes and diynes*

COMPOUND	REDUCING AGENTS	PRODUCTS	REFERENCES
Vinylacetylene . . . . . $\text{CH}_2=\text{CHC}\equiv\text{CH}$	Zn powder, NaOH Zn-Cu couple, alcohol	Butadiene Butadiene	(87, 133) (88, 192)
Diphenylvinylacetylene . . . . . $\text{C}_6\text{H}_5\text{CH}=\text{CHC}\equiv\text{CC}_6\text{H}_5$	Zn-Cu couple, alcohol	Diphenylbutadiene	(291)
Divinylacetylene . . . . . $\text{CH}_2=\text{CHC}\equiv\text{CCH}=\text{CH}_2$	Zn-Cu couple, alcohol	1,3,5-Hexatriene	(88)
Diacetylene . . . . . $\text{HC}\equiv\text{CC}\equiv\text{CH}$	Zn-Cu couple, alcohol	Butadiene	(88)
Diphenyldiacetylene . . . . . $\text{C}_6\text{H}_5\text{C}\equiv\text{CC}\equiv\text{CC}_6\text{H}_5$	Na (Li), ether Zn-Cu couple, alcohol	Polymers Diphenylbutatriene, $\text{C}_6\text{H}_5\text{CH}=\text{C}=\text{CH}-$ $\text{C}_6\text{H}_5$ , and 1,4-diphenyl-1,3- butadiene	(265) (291, 126)

When both R groups are alkyl, the product is a dimer:



When both R groups are aromatic, a monomeric dihydro compound is formed, and when one R group is hydrogen and the other aromatic, the product may be either a monomer or a dimer; thus, phenyldibenzofulvene (IV) gives a dimeric dihydro product, while  $\alpha$ -naphthyldibenzofulvene (V) yields a monomeric one.

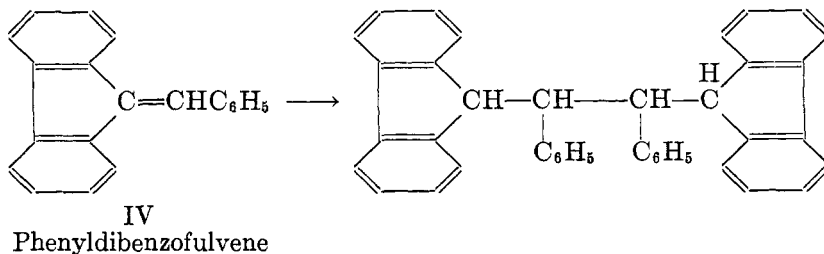

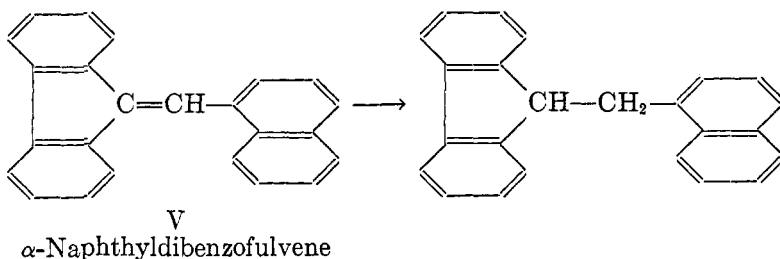

With the dibenzofulvenes (III) reduction by means of alkali metals in inert media followed by hydrolysis always occurs in the 1,2-position, at the external double bond, but the monobenzofulvenes (II) may yield either the 1,2- or the 1,4-reduction product, or both. Blum-Bergmann (39) has shown that reduction of triphenylbenzofulvene (VI) in this way gives both possible dihydro derivatives,

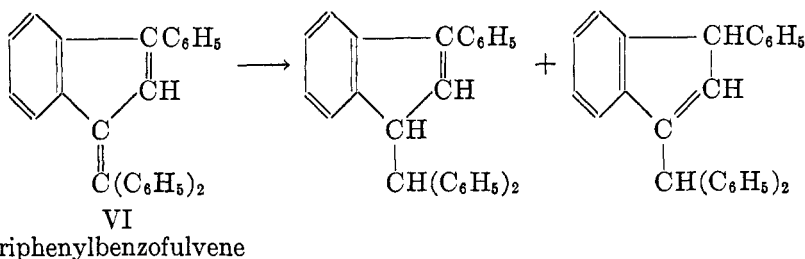

and diphenylbenzofulvene is converted to the 1,4-dihydro compound (39, 265).

Sodium and alcohol will also bring about the reduction of the fulvenes and their benzo analogs, regardless of the nature of the R groups. The reduction in some cases occurs in the 1,4-positions, as with dimethylbenzofulvene (300), and in other cases in the 1,2-positions, as with all the dibenzofulvenes (300) and with triphenylbenzofulvene (39).

Thiele and his students (35, 298, 299, 300, 341) and Sieglitz and Jassoy (281) have shown that the fulvenes, benzofulvenes, and dibenzofulvenes which contain at least one aryl or carboxyl group linked to the methylene carbon atom are reducible by aluminum amalgam in moist ether. When both the R groups are alkyl, this reagent does not bring about reduction (300). In the case of the dibenzofulvenes (III), reduction always occurs in the 1,2-positions (281, 299). With monobenzofulvenes (II) Thiele (298) originally considered that reduction always occurred in the 1,4-positions, to form indene derivatives,

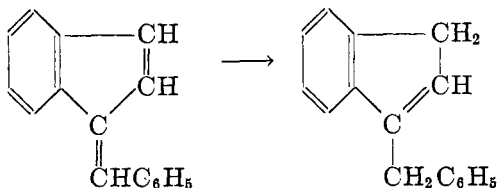

for the products of the reduction would condense with aldehydes to give substituted benzofulvenes. Wuest (341) showed, however, that the double bonds in



TABLE 6  
Reduction of hydrocarbons with crossed conjugated systems

COMPOUND REDUCED	REDUCING AGENTS AND CONDITIONS	PRODUCTS	REFERENCES
$\begin{array}{c} \text{CH}=\text{CH} \\   \\ \text{C}=\text{C}(\text{CH}_3)_2 \\   \\ \text{CH}=\text{CH} \end{array}$	Na (Li), ether	$\left[ \begin{array}{c} \text{CH}=\text{CH} \\   \\ \text{CH}-\text{C}(\text{CH}_3)_2 \\   \\ \text{CH}=\text{CH} \end{array} \right]_2$	(265)
$\begin{array}{c} \text{CH}=\text{CH} \\   \\ \text{C}=\text{C} \begin{array}{l} \text{R}_1 \\ \text{R}_2 \end{array} \\   \\ \text{CH}=\text{CH} \end{array}$ <p>where <math>\text{R}_1 = \text{R}_2 = \text{C}_2\text{H}_5</math>, <math>\text{R}_1 = \text{CH}_3</math>, and <math>\text{R}_2 = \text{C}_2\text{H}_5</math></p>	Al amalgam	No reduction	(299a)
$\begin{array}{c} \text{CH}=\text{CH} \\   \\ \text{C}=\text{C}(\text{C}_6\text{H}_5)_2 \\   \\ \text{CH}=\text{CH} \end{array}$	Al amalgam	No reduction	(299a)
$\begin{array}{c} \text{CH}=\text{CH} \\   \\ \text{C}=\text{C}(\text{C}_6\text{H}_5)_2 \\   \\ \text{CH}=\text{CH} \end{array}$	Na (Li), ether	$\begin{array}{c} \text{CH}=\text{CH} \\   \\ \text{CHCH}(\text{C}_6\text{H}_5)_2 \\   \\ \text{CH}=\text{CH} \end{array}$	(265)
$\begin{array}{c} \text{CH}=\text{CH} \\   \\ \text{C}=\text{C}(\text{C}_6\text{H}_4\text{OCH}_3)_2 \\   \\ \text{CH}=\text{CH} \end{array}$	Al amalgam	$\begin{array}{c} \text{CH}=\text{CH} \\   \\ \text{CHCH}_2\text{C}_6\text{H}_4\text{OCH}_3 \\   \\ \text{CH}=\text{CH} \end{array}$	(299a)
$\begin{array}{c} \text{C}_6\text{H}_5 \\   \\ \text{C}=\text{C}(\text{C}_6\text{H}_5)_2 \\   \\ \text{CH}=\text{CH} \end{array}$	Na (Li), ether	$\begin{array}{c} \text{C}_6\text{H}_5 \\   \\ \text{C}-\text{CH}(\text{C}_6\text{H}_5)_2 \\   \\ \text{CH}=\text{CH} \end{array}$	(29, 265)
$\begin{array}{c} \text{C}_6\text{H}_5 \\   \\ \text{C}=\text{C}(\text{C}_6\text{H}_5)_2 \\   \\ \text{CH}=\text{CH} \end{array}$	Al amalgam	$\begin{array}{c} \text{C}_6\text{H}_5 \\   \\ \text{C}-\text{CH}_2\text{Y} \\   \\ \text{CH}=\text{CH} \end{array}$	(300)
$\begin{array}{c} \text{C}_6\text{H}_5 \\   \\ \text{C}=\text{C}(\text{C}_6\text{H}_5)_2 \\   \\ \text{CH}=\text{CH} \end{array}$	Al amalgam	$\begin{array}{c} \text{C}_6\text{H}_5 \\   \\ \text{C}-\text{CH}_2\text{Y} \\   \\ \text{CH}=\text{CH} \end{array}$	(298)











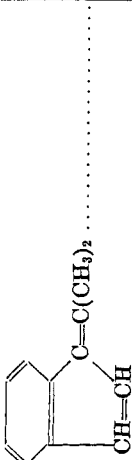
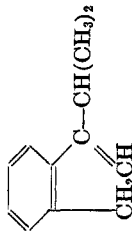
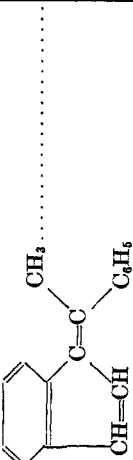
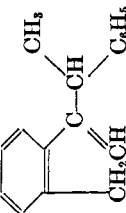
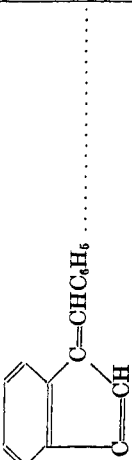
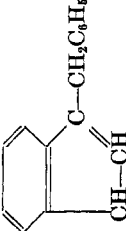

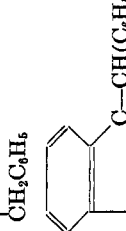
	<p>Na, ether Al amalgam</p>	<p>Polymer No reduction</p> 	<p>(265) (300)</p>
	<p>Na, alcohol</p>		<p>(300)</p>
	<p>Al amalgam</p>		<p>(300)</p>
	<p>Al amalgam</p>		<p>(298)</p>
	<p>Na, ether</p>	 <p>and</p> 	<p>(39)</p>

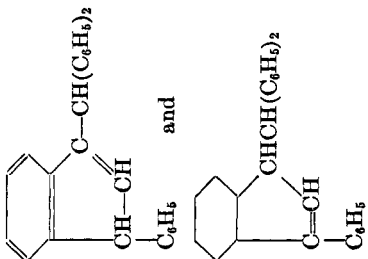
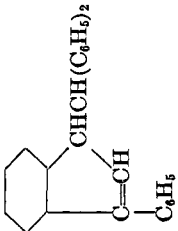
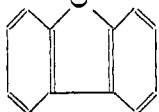
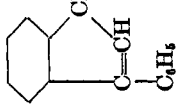
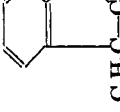
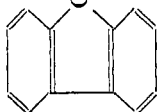
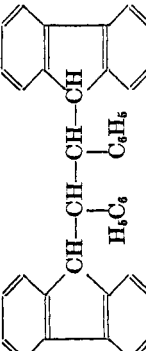
TABLE 6—Concluded

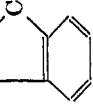
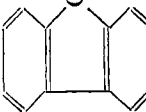
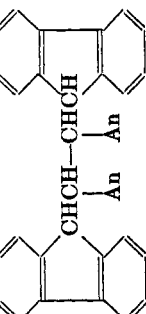
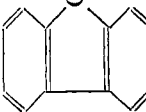
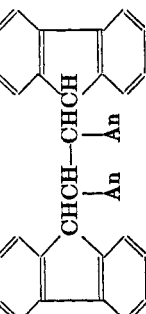
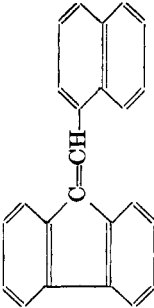
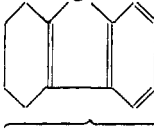
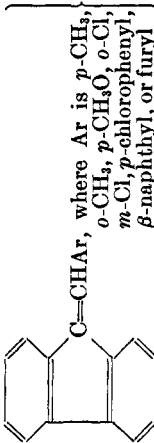
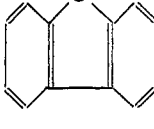
COMPOUND REDUCED	REDUCING AGENTS AND CONDITIONS	PRODUCTS	REFERENCES
 $\text{C}=\text{CHC}_6\text{H}_5$ .....	Na, alcohol	 $\text{CHCH}(\text{C}_6\text{H}_5)_2$ and  $\text{C}_6\text{H}_5\text{C}=\text{CH}$	(39)
 $\text{C}=\text{CHC}_6\text{H}_5$ .....	Na, ether	 $\text{C}_6\text{H}_5\text{C}=\text{CH}$	(265, 267a)
 $\text{C}=\text{CHC}_6\text{H}_5$ .....	Na, liquid $\text{NH}_3$	 $\text{CHCH}_2\text{C}_6\text{H}_5$	(267a)
 $\text{C}=\text{CHC}_6\text{H}_4\text{OCH}_3(p)$ .....	Al amalgam	 $\text{CHCH}$	(298)
 $\text{C}=\text{CHC}_6\text{H}_4\text{OCH}_3(p)$ .....	Na, ether	 $\text{CHCH}$	(267a)

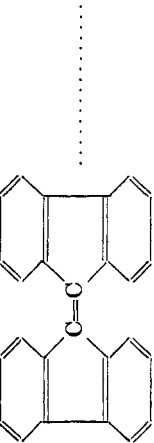
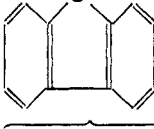

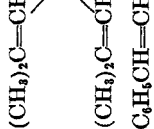
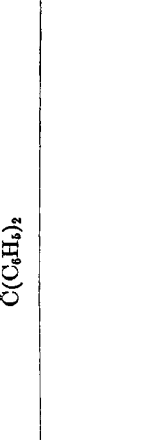
 <p>.....</p>	<p>Na, ether</p>		<p>(267a)</p>
 <p>.....</p>	<p>Al amalgam</p>		<p>(281)</p>
 <p>.....</p>	<p>Al amalgam</p>	<p>No reduction</p>	<p>(298)</p>
 <p>.....</p>	<p>Al amalgam</p>		<p>(298)</p>
 <p>.....</p>	<p>Na, ether</p>		<p>(265)</p>
 <p>.....</p>	<p>Na, ether</p>		<p>(265)</p>

It is more probable, however, that the compound obtained from the addition of sodium is tetraphenyl-1-propene. Wooster and Ryan (339) have shown that the allene is reduced by sodium in liquid ammonia to tetraphenylpropane, and very possibly, in the light of Hückel's work (130), the reaction is a stepwise one, forming tetraphenylpropene as intermediate.

*F. The stereochemical course of reduction*

Much of the work on the reduction of acetylenes has centered around the geometrical configuration of the olefins obtained; until recently, this work was

TABLE 7  
*Reduction of hydrocarbons with cumulated double bonds*

COMPOUND REDUCED	REDUCING AGENTS	PRODUCTS	REFERENCES
$(C_6H_5)_2C=C=C(C_6H_5)_2$ . . . . .	Na, ether	$(C_6H_5)_2CHCCH(C_6H_5)_2$ ?	(265a)
	Li, ether	$(C_6H_5)_2CHCH$ — $CHC_6H_5$ 	(265a)
	Na (K), liquid NH <sub>3</sub>	$(C_6H_5)_2CHCH_2CH(C_6H_5)_2$	(339)
	Na, alcohol	$(C_6H_5)_2CHCH_2CH(C_6H_5)_2$	(317)
	Na amalgam	No reduction	(317)
	Al amalgam	No reduction	(317)
	Zn, acetic acid	No reduction	(317)
$(C_6H_5)_2C=C=C=C(C_6H_5)_2$ . . . . .	HI, P, acetic acid	$(C_6H_5)_2CHCH=C(C_6H_5)_2$ and $(C_6H_5)_2CHCH_2CH(C_6H_5)_2$	(317)
	Na, amyl alcohol	$(C_6H_5)_2CHCH_2CH_2CH(C_6H_5)_2$	(46a)
	Zn, acetic acid	$(C_6H_5)_2C=CHCH=C(C_6H_5)_2$	(46a)
	Zn, H <sup>+</sup>	Rapid reduction	(176)
$(C_6H_5)_2C=C=C=C(C_6H_5)_2$	Zn, H <sup>+</sup>	Rapid reduction	(176)
$C_6H_5C=C=C(CH_3)_2$ . . . . .	Na, alcohol	$C_6H_5CHCH=C(CH_3)_2$ 	(168b)

largely confined to tolane and the acetylenic acids. Farkas and Farkas (90) have pointed out that, since the reduction of an unsaturated linkage in all probability occurs by a stepwise mechanism (see section II B), then the intermediate fragment formed by addition of the first proton has time to adjust its substituents to a position of minimum potential energy before the second stage of the addition occurs. On this basis, the chemical reduction of disubstituted acetylenes should yield the *trans* olefins, and reduction of suitably substituted olefins should give the meso saturated compounds, since these are, in general, the more stable configurations. On the other hand, if catalytic hydrogenation occurs by simultaneous addition of hydrogen to both carbon atoms of the unsaturated



linkage (90, 91, 92), the product should be the labile isomer, *cis* olefins from acetylenes, meso saturated compounds from *cis* olefins, and racemic saturated compounds from *trans* olefins. The information in the literature, in the main, confirms this theory, although there are exceptions, and the problem is complicated by the fact that much of the work has been done with compounds the reduction products of which can fairly readily be converted into their stereoisomers.

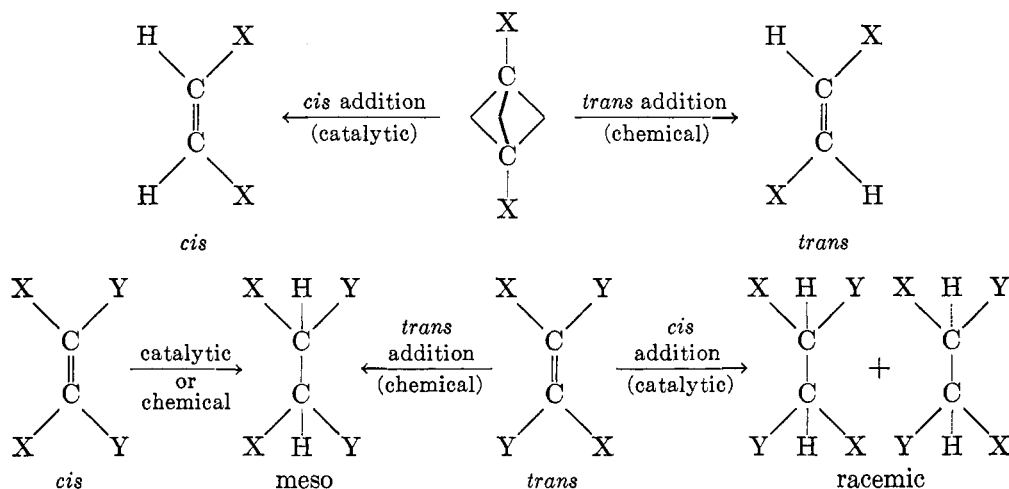

Gonzales (120) found that reduction of stearolic acid with zinc and acetic acid resulted in the *trans* olefinic acid, while catalytic hydrogenation yielded the *cis* form. Phenylpropionic acid has been studied extensively. Aronstein (16) and Fischer (105) obtained cinnamic acid when zinc dust and acetic acid were used as the reducing agent, and Fischer considered this to be the primary reduction product, for *cis*-cinnamic acid is not converted to *trans*-cinnamic acid under the conditions used. Cinnamic acid is likewise formed when phenylpropionic acid is treated with sodium in alcohol (16), although, since *cis*-cinnamic acid is easily converted to *trans*-cinnamic acid under these conditions, the latter may have been formed by rearrangement. Ott (226) considered that the stereochemical course of reduction of a triple bond is related to the reduction potential of the reducing agent; he postulated that reduction by the more noble metals should yield the *cis* forms, while the less noble metals should tend to yield the *trans* forms, and suggested that as the velocity of reduction is increased, a point should be reached where no olefin is obtained, the product being a mixture of the acetylene and the saturated compound. He tested this theory on phenylpropionic acid, and reported the results given in table 8.

The chemical reduction of toluene can give either the *cis* or the *trans* form of stilbene, depending on the conditions. With sodium in methyl alcohol, or with zinc and acetic acid (291), the product is the ordinary (or *trans*) form of stilbene, but it should be pointed out that *cis*-stilbene is easily changed to the *trans* form by sodium (265a, 340a). *cis*-Stilbene is formed when toluene is reduced in aqueous medium with the zinc-copper couple (291).

Bourguel (43) reported that tetramethylbutyndiol is reduced to the *trans* olefinic glycol by sodium and alcohol; subsequent work by Zalkind (348) and by Johnson (147a) has shown, however, that the product is a polymorphic form of the original acetylenic glycol.

Less work has been done on the stereochemical course of the reduction of olefins than of acetylenes. Ott (227) found that *trans*-dimethylstilbene was reduced by sodium and alcohol to a stable equilibrium mixture of meso and racemic 2,3-diphenylbutanes. Since *cis*-dimethylstilbene is rapidly converted to the *trans* isomer by sodium, its reduction by alkali metals is really that of the *trans* form. Addition of alkali metals to the dimethylstilbenes, followed by hydrolysis, yields mesodiphenylbutane (265a).

Schlenk and Bergmann (265a) reported that addition of sodium and lithium to the *cis* and *trans* forms of stilbene took different stereochemical courses; more careful work by Wright (340a) has, however, shown that this is not true. Carbonation of the alkali-metal addition products yields a mixture of the meso- and

TABLE 8

*Reduction of phenylpropionic acid in ammoniacal ammonium chloride solution at 20°C. (226)*

REDUCING AGENTS	PRODUCTS
Zn.....	Allocinnamic acid (10%)
Zn-Ag couple.....	Allocinnamic acid (24%)
Zn-Cu couple.....	Allocinnamic acid (37%)
Mn.....	Mainly allocinnamic acid, with 4 per cent of <i>trans</i> isomer
Mg, Ba amalgam, Na amalgam	Hydrocinnamic acid (50%) and phenylpropionic acid (50%)
Cr <sup>++</sup>	Mixture of <i>cis</i> - and <i>trans</i> -cinnamic acids
Ti <sup>+++</sup>	Allocinnamic acid

*dl*-diphenylsuccinic acids, regardless of the alkali metal or stilbene used. The nature of the solvent exerts a marked effect on the relative amounts of the two acids formed, however.

The recent work of Campbell and Eby (56, 57) has given considerable support to the postulates of Farkas and Farkas (90), for they have shown that dialkylacetylenes are smoothly and easily reduced to *trans* olefins by sodium in liquid ammonia. Raman-spectra evidence indicates that the *trans* olefins so obtained are free from their *cis* isomers, and the configurations have been proved by freezing-point, dielectric-constant, and Raman-spectra data. Since *cis* olefins containing only alkyl groups are not converted to the *trans* forms by treatment with sodium (57, 363), the *trans* olefins obtained in this work must be the primary reduction products, and consequently, the reduction, in all probability, occurs by a stepwise mechanism. The *trans* isomers of all the straight-chain hexenes and octenes have been prepared in this way, as well as the *trans* forms of 2-methyl-3-octen-2-ol and 3,3-dimethyl-4-nonene. Reduction of dialkylacetylenes by lithium in liquid ammonia takes the same course, and yields the *trans* olefins (57).

The data on the stereochemical reduction of acetylenes and olefins are summarized in table 9.

The stereochemical configuration of the new double bond formed by 1,4-reduction of a conjugated diene varies with the nature of the reducing agent, and there seem to be no generalizations possible from the few cases that have been reported. Addition of sodium or lithium in an inert solvent, followed by hydrolysis, yields the *cis* form of 2-butene from butadiene (363), and *cis*-1,4-diphenyl-2-butene from 1,4-diphenylbutadiene (265a), but the *trans* olefin has been ob-

TABLE 9  
*Configuration of products obtained by chemical reduction of acetylenes and olefins*

COMPOUND REDUCED	REDUCING AGENTS	PRODUCTS	REFERENCES
RC≡CR where R is ethyl, propyl, butyl.....	Na, liquid NH <sub>3</sub>	<i>trans</i> RCH=CHR	(56, 57)
2-Hexyne.....	Na (Li), liquid NH <sub>3</sub>	<i>trans</i> -2-Hexene	(56, 57)
2-Octyne.....	Na (Li), liquid NH <sub>3</sub>	<i>trans</i> -2-Octene	(57)
3-Octyne.....	Na, liquid NH <sub>3</sub>	<i>trans</i> -3-Octene	(56, 57)
3,3-Dimethyl-4-nonyne....	Na, liquid NH <sub>3</sub>	<i>trans</i> -3,3-Dimethyl-4-nonyne	(60)
2-Methyl-2-hydroxy-3-octyne	Na, liquid NH <sub>3</sub>	<i>trans</i> -2-Methyl-2-hydroxy-3-octene	(57)
Stearolic acid..... CH <sub>3</sub> (CH <sub>2</sub> ) <sub>7</sub> C≡C(CH <sub>2</sub> ) <sub>7</sub> -COOH	Zn, acetic acid	Elaidic acid ( <i>trans</i> )	(120)
Behenolic acid..... CH <sub>3</sub> (CH <sub>2</sub> ) <sub>7</sub> C≡C(CH <sub>2</sub> ) <sub>11</sub> -COOH	Zn, acetic acid	Brassicic acid ( <i>trans</i> )	(120)
Diphenylacetylene.....	Na, methyl alcohol Zn, acetic acid Zn-Cu couple	<i>trans</i> -Stilbene <i>trans</i> -Stilbene <i>cis</i> -Stilbene	(16) (16) (291)
Phenylpropionic acid.....	Na, alcohol Zn, acetic acid	<i>trans</i> -Cinnamic acid <i>trans</i> -Cinnamic acid	(16) (16, 105)
Dimethylstilbene.....	Na, ether  Na, alcohol	Diphenylethane (30% racemic, 70% meso) Diphenylethane (50% racemic, 50% meso)	(227) (227)

tained in the same way from 1,1,4,4-tetraphenylbutadiene (38, 265a). Sodium amalgam causes the formation of *trans* olefins from di- and tetra-phenylbutadienes; it is possible that a stereochemical conversion occurs here (265a). Reduction of 2,6-dimethyl-3,5-octadiene by sodium in liquid ammonia leads to a mixture of the *cis* and *trans* forms of 2,6-dimethyl-4-octene, with the *trans* form predominating. In this case, the configurations were established by Raman spectra measurements (77). These data are summarized in table 10.

#### G. Reduction of aromatic hydrocarbons

A large amount of work has been done on the addition of alkali metals to aromatic hydrocarbons, and on the reduction of these hydrocarbons by alkali

metals in reactive solvents. Benzene and its simple homologs do not, in general, add alkali metals, and are not reduced by them. Most of the polynuclear hydrocarbons, on the other hand, do add alkali metals, especially lithium, and are reduced by these metals in alcohol or in liquid ammonia. Addition of lithium takes place with increasing ease in the order: naphthalene, phenanthrene, anthracene (265). Aromatic compounds are not usually attacked by sodium amalgam or aluminum amalgam (291), although anthracene is reduced by both (143, 291) and terephthalic acid is reduced by sodium amalgam (328). The addition of hydrogen or metals to polynuclear hydrocarbons has a strong tendency to occur in the 1,4-positions, and in this respect these compounds resemble the 1,4-diarylbutadienes. When the reaction is carried out in alcohol or liquid am-

TABLE 10  
Configuration of olefins formed by chemical reduction of conjugated hydrocarbons

COMPOUND REDUCED	REDUCING AGENTS	PRODUCT	CONFIGURATION	REFERENCES
Butadiene.....	Na (Li), ether, ethylaniline	2-Butene	<i>cis</i>	(363)
1,4-Diphenylbutadiene....	Na (Li), ether	1,4-Diphenyl-2-butene	<i>cis</i>	(265a)
	Na amalgam	1,4-Diphenyl-2-butene	<i>trans</i>	(265a)
1,1,4,4-Tetraphenylbutadiene.....	Na (Li), ether	1,1,4,4-Tetraphenyl-2-butene	<i>trans</i>	(265a)
	Na amalgam	1,1,4,4-Tetraphenyl-2-butene	<i>trans</i>	(265a)
5-Methyl-2,4-heptadiene...	Na, liquid NH <sub>3</sub>	5-Methyl-3-heptene	<i>trans</i> mainly, some <i>cis</i>	(77)
2,3-Diphenylbutadiene....	Na, liquid NH <sub>3</sub>	2,3-Diphenylbutane	meso	(12)

monia, a rearrangement of the primary reaction product is apt to occur, so that the product isolated is not always the 1,4-dihydro compound. Recent work by Scott (276, 277, 278, 318) and by Jeannes and Adams (146) has shown that the addition of sodium, which in many cases is extremely slow in ether, is much more rapid in such solvents as the glycol ethers and dimethyl ether. The close parallel between the addition of alkali metals and reduction by these metals in reactive solvents gives strong support to Willstätter's theory (328),—as opposed to Baeyer's (23),—regarding the mechanism of this reduction (see section II B).

### 1. Reduction of naphthalene

Naphthalene adds sodium very slowly in diethyl ether, lithium more readily, and in both cases hydrolysis yields the 1,4-dihydro compound (265). Scott and Walker (278, 318) have found that addition of sodium in ethylene glycol di-

methyl ether occurs more readily, and although but 1 gram-atom of sodium is taken up per mole of naphthalene, hydrolysis yields the 1,4-dihydro compound; possibly a complex of the type  $C_{10}H_8Na_2 \cdot C_{10}H_8$  is formed.

Naphthalene is easily reduced by sodium in liquid ammonia. Lebeau and Picon (183), who first studied this reaction, carried it out at room temperature, and obtained the 1,2,3,4-tetrahydronaphthalene and sodium amide. They considered that reduction was preceded by the formation of an organo-sodium compound, for at  $-10^\circ C$ . and below, the solution had the red color of organo-sodium solutions, and by adding ethyl bromide to the colored solution they obtained an ethylated product. Subsequent workers have confirmed and amplified these results.

Wooster and Smith (340), in the course of a detailed study of this reaction, showed that the 'nascent'-hydrogen theory of Baeyer (23), proposed to explain such reduction, is untenable, for when naphthalene and sodium were allowed to react in liquid ammonia, titration showed that only four atoms of sodium reacted per molecule of naphthalene, regardless of the presence of excess sodium. These workers believed that a 1,2,3,4-tetrasodium derivative was formed, and that this was three-fourths ammonolyzed, even at low temperatures. More recent work of Hückel and Bretschneider (130) shows, however, that the reaction of sodium with naphthalene in liquid ammonia follows a stepwise course. At low temperatures ( $-75^\circ$  to  $-60^\circ C$ .) a 1,4-disodium naphthalene is formed (this is, of course, analogous to the 1,4-addition of sodium to 1,4-diphenylbutadiene). This disodium salt is stable at these low temperatures, but at higher temperatures it is ammonolyzed, yielding 1,4-dihydronaphthalene. At  $-33^\circ C$ . this substance, in the presence of sodium amide, rearranges to the 1,2-dihydronaphthalene, which, since it is a 1-arylolefin, is reduced by sodium in liquid ammonia to tetralin.

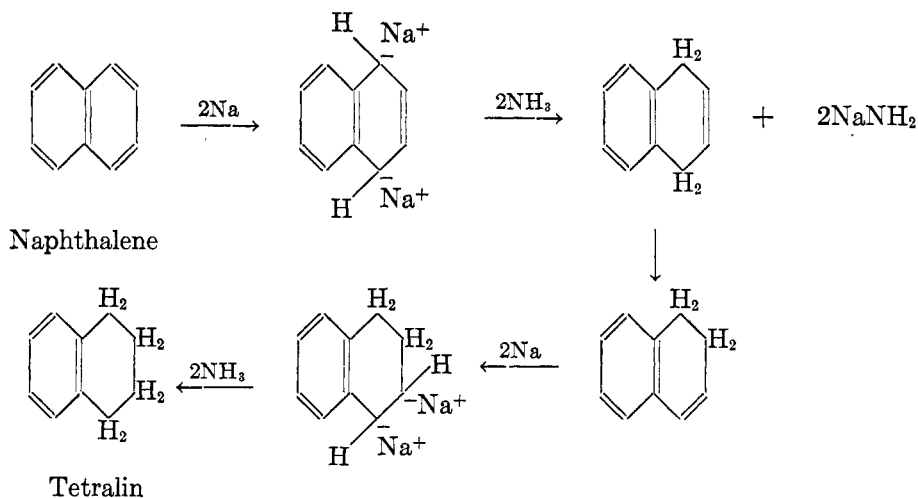

Since calcium in liquid ammonia reacts with naphthalene as does sodium (130), Hückel considers that the real mechanism of the reduction is the addition of

TABLE II  
*Reduction of aromatic hydrocarbons by chemical reducing agents*

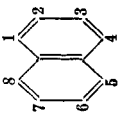
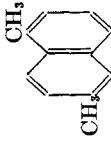
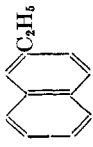
COMPOUND REDUCED	REDUCING AGENTS AND CONDITIONS	PRODUCTS	REFERENCES
Naphthalene..... 	Na, ether Li or K, ether Na, glycol ether  Na (Ca), liquid NH <sub>3</sub> , -75°C. Na, liquid NH <sub>3</sub> , -33°C.  Na, liquid NH <sub>3</sub> , room temperature  Na, ethyl alcohol Na, ethyl alcohol, solvent naphtha  Ca, ethyl alcohol Na, amyl alcohol Na amalgam Ca(NH <sub>3</sub> ) <sub>6</sub> , room temperature Na, amyl alcohol	No addition 1,4-Dihydro 1,4-Dihydro  1,4-Dihydro 1,2-Dihydro and 1,2,3,4-tetrahydro 1,2,3,4-Tetrahydro  1,4-Dihydro 1,2,3,4-Tetrahydro  1,4-Dihydro 1,2,3,4-Tetrahydro  1,4-Dihydro 1,2,3,4-Tetrahydro No reduction Tetrahn and decalin 5,8-Dihydro	(265a) (265a) (276, 278, 318) (130) (130, 340)  (183)  (25) (27)  (207) (255) (291) (157) (209)
1,6-Dimethylnaphthalene..... 	Na, amyl alcohol	Mixture of dihydro products	(193)
2-Ethyl naphthalene..... 			

Anthracene..... 	Na, ether Na, glycol ether Na, liquid NH <sub>3</sub> , -33°C. or room temperature Na (Ca), alcohol Na, amyl alcohol Na amalgam, alcohol Na, Al, Mg amalgams HI + P, 160-170°C. 220°C. 250°C.	9, 10-Dihydro Disodium salt 9, 10-Dihydro 9, 10-Dihydro 9, 10-Dihydro 9, 10-Dihydro 9, 10-Dihydro Hexahydro Perhydro 9, 10-Dihydro 9, 10-Dihydro 9, 10-Dihydro Slow addition 9, 10-Dihydro 9, 10-Dihydro With two sodium, incomplete re- action; with four sodium, a non-uniform product Tetrahydro, unproved structure	(264, 265a) (277) (184, 214, 323) (323, 207) (26) (291) (143) (201)  (265a) (135) (265) (265a) (265a) (146) (130)  (184)
9, 10-Diphenylanthracene.....	Na, liquid NH <sub>3</sub> , room tempera- ture Na, alcohol	Tetrahydro, unproved structure	(184)
Phenanthrene..... 	Na, liquid NH <sub>3</sub> , room tempera- ture Na, alcohol Na amalgam Zn + Pd, HCl HI + P, 200°C. 240°C. Na, glycol ether Na, liquid NH <sub>3</sub> , room tempera- ture Na, amyl alcohol HI + P	9, 10-Dihydro and 5, 6, 7, 8-tetrahydro No reduction Tetrahydro entirely Tetrahydro Octahydro Disodium salt Tetrahydro, unproved structure 1, 2, 3, 4-Tetrahydro Decahydro	(274)  (291) (49) (122)  (277) (184)  (26, 47) (194)
Acenaphthene..... 			

TABLE 11—Continued

COMPOUND REDUCED	REDUCING AGENTS AND CONDITIONS	PRODUCTS	REFERENCES
1,2-Benzanthracene..... 	Na, ether Na, amyl alcohol	7,12-Dihydro 1,2,3,4,7,12-Hexahydro	(22, 103) (103)
7-Methylbenzanthracene..... 	Na, ether Na, amyl alcohol	7,12-Dihydro 1,2,3,4,7,12-Hexahydro	(103) (103)
Dibenzanthracene..... 	Na (Li), ether	7,14-Dihydro	(22)



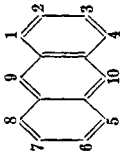
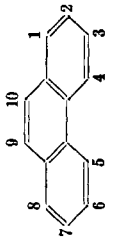
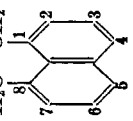

TABLE II—*Concluded*

COMPOUND REDUCED	REDUCING AGENTS AND CONDITIONS	PRODUCTS	REFERENCES
Fluorene 	Na, liquid NH <sub>3</sub>	Chiefly substitution	(184)
Benzene	Na, liquid NH <sub>3</sub> Na, liquid NH <sub>3</sub> , CH <sub>3</sub> OH Ca(NH <sub>2</sub> ) <sub>6</sub> , room temperature Sr, Ba, Li-NH <sub>3</sub> complexes HI + P Na, liquid NH <sub>3</sub> Na, liquid NH <sub>3</sub> , H <sub>2</sub> O or CH <sub>3</sub> OH HI + P, 310°C. Ca(NH <sub>2</sub> ) <sub>6</sub>	No reaction 1,4-Cyclohexadiene Cyclohexene Cyclohexene, in poorer yields Not readily attacked No reaction 1,4-Dihydro Dihydro (?) 1-Methyl-1-cyclohexene	(184) (336) (154, 157) (155) (24) (184) (336, 338) (24) (154, 157)
Toluene	Ca(NH <sub>2</sub> ) <sub>6</sub> HI + P, 310°C. Ca(NH <sub>2</sub> ) <sub>6</sub> Ca(NH <sub>2</sub> ) <sub>6</sub> Ca(NH <sub>2</sub> ) <sub>6</sub> Ca(NH <sub>2</sub> ) <sub>6</sub>	1,3-Dimethyl-3-cyclohexene Tetrahydroxytolene 1,4-Dimethyl-3-cyclohexene Non-homogeneous product Difficult to reduce; gives 1,3,5-trimethyl-1-cyclohexene	(154) (24) (154) (154) (154)
Xylenes: meta	HI + P, 350°C. Na, ether Li, ether Na, liquid NH <sub>3</sub> , -65°C. Na, liquid NH <sub>3</sub> , room temperature	Hexahydro Addition very slow Dihydro, 1,4- (?) 1-Phenyl-1-cyclohexene Tetrahydro	(24) (265a) (265a) (130) (184)
Biphenyl 	Na, amyl alcohol Na, ether Na, liquid NH <sub>3</sub>	Tetrahydro 1',4'-Dihydro (?) 1',2'-Dihydro and C <sub>18</sub> H <sub>14</sub>	(26) (265a) (130)
Terphenyl 	Na amalgam, pH 10-12 Na amalgam, pH 9	1,4-Dihydro p-Toluic acid	(328) (328)
Terephthalic acid			

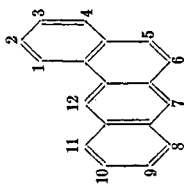
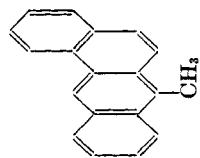
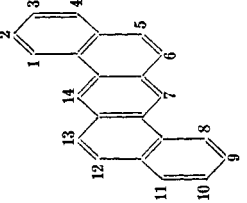
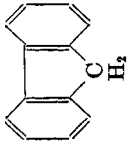
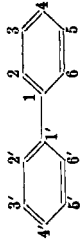
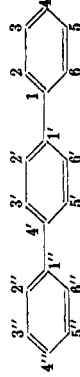
electrons to the 1,4-positions of the naphthalene, to form a doubly negative ion (see section II B).

The tendency of naphthalene to react similarly to 1,4-diphenylbutadiene is further exemplified by its reduction with sodium and ethyl alcohol, which yields the 1,4-dihydro derivative (25). If amyl alcohol is used instead of ethyl, the 1,4-dihydronaphthalene is the initial product, but the presence of alkali and the higher temperature causes this to rearrange to the 1,2-dihydro isomer, which is further reduced to tetralin (255).

The chemical reduction of naphthalene homologs has not been studied to any great extent. Mayer and Schulte (209) report the reduction of 1,6-dimethylnaphthalene with sodium and amyl alcohol as forming the 5,8-dihydro derivative by 1,4-reduction. Under the same conditions, 2-ethylnaphthalene forms a mixture of dihydro compounds (193).

Acenaphthene adds sodium in ethylene glycol dimethyl ether; the structure of the product has not been established, but presumably it is the 1,4-compound (277). Reduction of acenaphthene by sodium in liquid ammonia (184) and by sodium and amyl alcohol (47) is similar to that of naphthalene; it yields the tetralin.

## 2. Reduction of anthracene

This hydrocarbon is more easily reduced by alkali metals than are naphthalene and phenanthrene, and in reduction, as in other reactions, it is attacked in the 9,10-positions; the 9,10-dihydroanthracene, containing as it does two independent benzene rings, is not further attacked by chemical reducing agents.

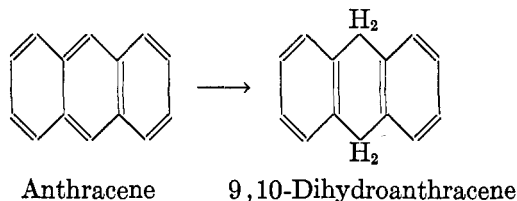

Anthracene has been reduced to the 9,10-dihydro derivative by the addition of sodium or lithium in ethylene glycol ethers (277) or in diethyl ether (264,265), followed by hydrolysis; by sodium or potassium in liquid ammonia (184,214); and by sodium or calcium and alcohol (207,323). Even the use of sodium and amyl alcohol does not carry the reduction beyond the dihydro stage (26,122). Unlike many of the other polynuclear hydrocarbons, anthracene can be reduced by sodium amalgam (122,143) and by aluminum and magnesium amalgams (143).

9,10-Diphenylanthracene, like anthracene, is reduced in the 9,10-positions by sodium and alcohol and by sodium in liquid ammonia (135); on treatment with sodium or lithium in ether, it forms the 9,10-dimetallic salt (265a). In connection with the stereochemical course of chemical reductions, it is interesting to note that hydrolysis of the disodium salt produces a 9,10-dihydro-9,10-diphenylanthracene which is a stereoisomer of the one obtained by reduction with sodium and amyl alcohol (265a).



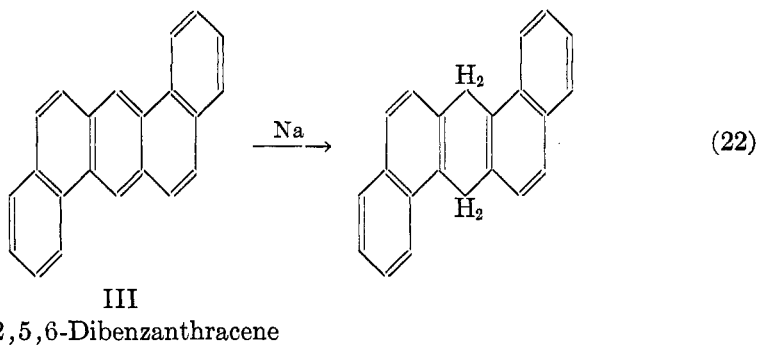
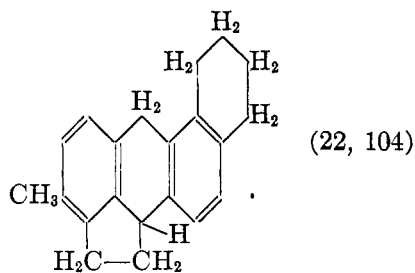
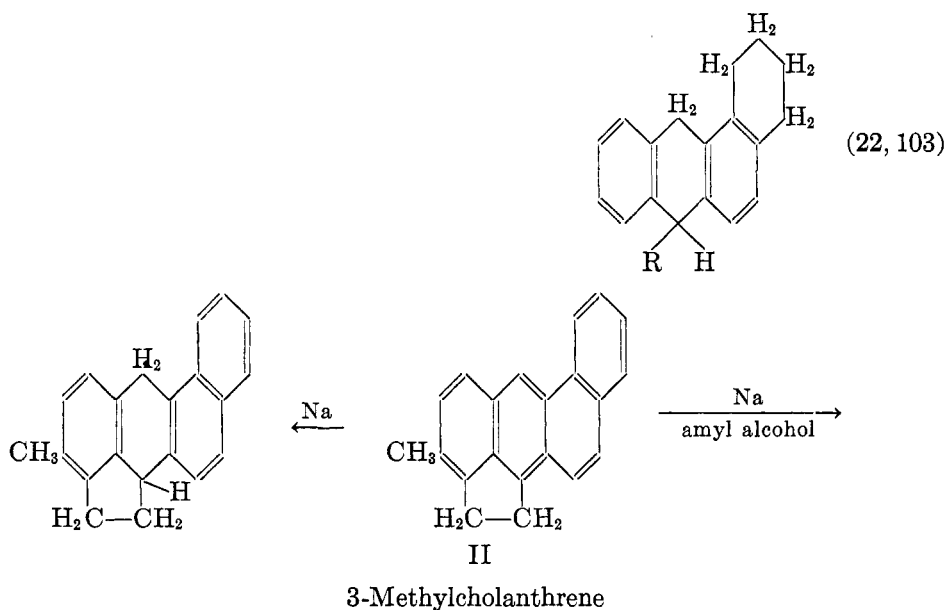

Pyrene in ether solution forms a dilithium salt (30), but hydrolysis of this salt regenerates the original compound, indicating that the dihydro compound is unstable and autooxidizable. It, therefore, cannot be the dihydro compound (IV), which would be formed if the addition took the same course as it does in phenanthrene, for compound IV has been obtained by catalytic hydrogenation of pyrene, and it is stable. As in the case of phenanthrene, reduction of pyrene by

sodium and amyl alcohol leads to the addition of six hydrogen atoms, and a mixture of two hexahydro-pyrenes is obtained (66).

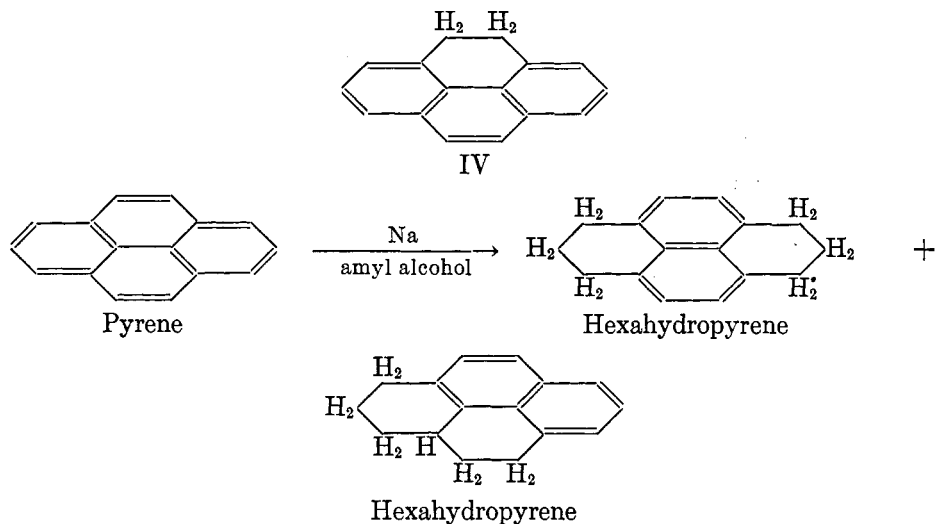

#### 4. Reduction of benzene and its derivatives

Although benzene and the alkylbenzenes do not, in general, react with alkali metals, the aryl-substituted ones do. Sodium reacts very slowly with biphenyl in ether solution, lithium more readily, to yield a salt to which Schlenk and Bergmann (265) assigned the 1,4-structure.

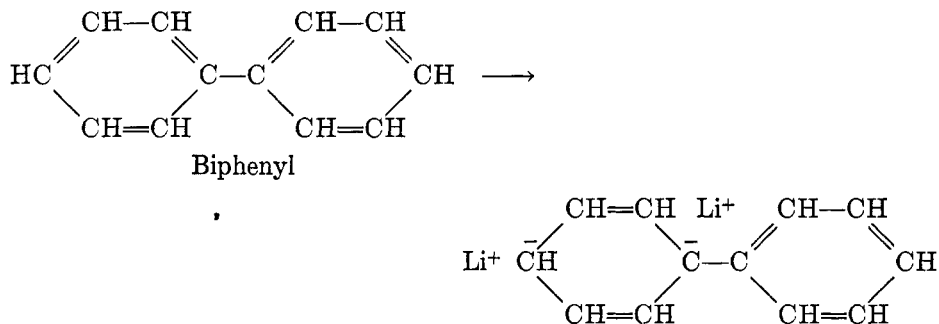

Hückel and Bretschneider (130), however, found that biphenyl reacts with sodium in liquid ammonia at low temperatures to give a tetrahydro compound, and they formulated the reaction as involving first 3,4-addition, followed by 1,4-addition to the phenylcyclohexadiene formed as intermediate.

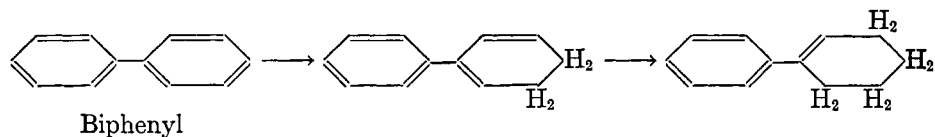

Terphenyl, on treatment with sodium in ether, yields a disodium salt, which Schlenk and Bergmann (265) considered resulted from 1,4-addition to the central benzene ring.

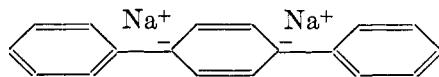

Hückel and Bretschneider (130), on the other hand, obtained a dihydroterphenyl from the action of sodium in liquid ammonia, to which they assigned the following structure, since the compound contained a conjugated system:

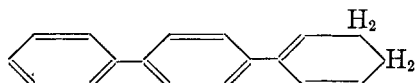

There are two exceptions to the statement that benzene and toluene are not attacked by alkali metals. No metal salt is obtained when these hydrocarbons are treated with sodium or lithium in inert solvents, and no reduction takes place when they are treated with sodium and alcohol, or sodium in liquid ammonia under ordinary conditions. Wooster and Godfrey (338) have, however, found that when a solution of toluene and sodium in liquid ammonia is treated with water, far less than the theoretical amount of hydrogen is evolved, and a highly unsaturated compound is obtained. This may be a true case of reduction by 'nascent' hydrogen, since no reaction occurs between the sodium and the toluene in the absence of water. A recent patent issued to Wooster (336), in extension of this work, describes the preparation of 1,4-dihydrobenzene and 1,4-dihydrotoluene by treating the hydrocarbons with sodium in liquid ammonia in the presence of a hydrolytic agent such as methyl alcohol.

Substitution of one or more of the hydrogen atoms of the benzene ring by hydroxyl or carboxyl groups renders the products more susceptible to reduction by chemical agents; although a detailed discussion of these cases is beyond the scope of this article, mention should be made of the results of Willstätter and his students on the reduction of terephthalic acid by pure sodium amalgam (328). The course of this reduction is markedly affected by the hydrogen-ion concentration of the medium; at a pH of 10-12, nuclear reduction occurs, and a mixture of the  $\Delta^{2,5}$ -dihydro and  $\Delta^2$ -tetrahydro acids is obtained.

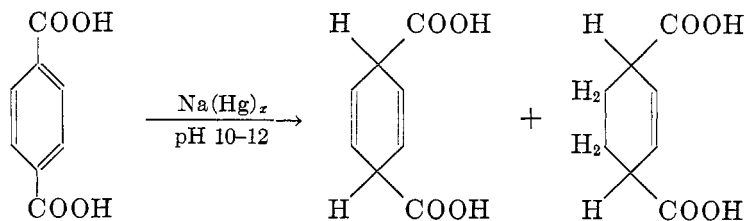

Terephthalic acid

When, on the other hand, the pH is maintained at 9-9.8 by the use of buffers, nuclear reduction ceases to be the main reaction, and instead, one of the carboxyl groups is attacked, with the formation of *p*-toluic acid.

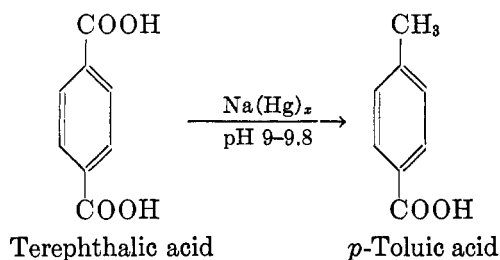

Similar results have been obtained with benzoic acid (210). Reduction by sodium amalgam in alkaline solution yields a tetrahydro acid, whereas reduction in acid medium forms benzyl alcohol.

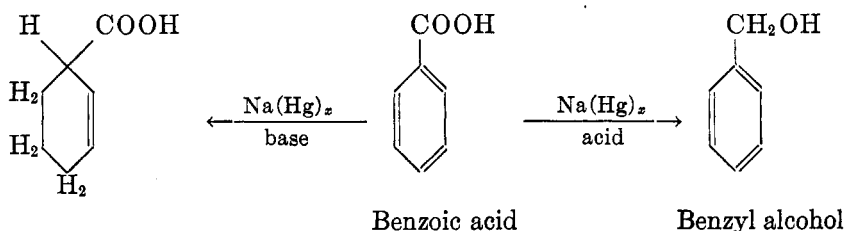

Calcium ammonia,  $\text{Ca}(\text{NH}_3)_6$ , made by passing ammonia vapors over metallic calcium, is a powerful reducing agent for aromatic compounds. It will reduce benzene and its homologs at room temperatures to cyclohexene derivatives, in yields as high as 90 per cent. With alkylbenzenes, the double bond of the cyclohexene is linked to the same carbon atom as the alkyl group (154, 157). The ammonia complexes of lithium, strontium, and barium can also be used (155), but they are much less effective.

Hydriodic acid and red phosphorus may be used to reduce most aromatic hydrocarbons; frequently a mixture of products is obtained, and the reduction can be made complete if a sufficiently high temperature is used. Other methods of reduction are generally preferable.

The aromatic hydrocarbons are not, as a rule, reduced by zinc and acid, but Breteau (49) has reported the reduction of phenanthrene with zinc activated by palladium chloride, in hydrochloric acid solution. The tetrahydro derivative was obtained, regardless of the amount of reducing agent used, and no dihydro- or hexahydro-phenanthrene could be isolated. This may possibly be a case of catalytic hydrogenation, in which the palladium functioned as catalyst and the hydrogen was generated by interaction of the zinc and hydrochloric acid.

#### *H. Reduction of $\alpha,\beta$ -unsaturated carbonyl compounds*

The presence of a carbonyl group adjacent to the carbon-carbon unsaturation activates the latter, so that reduction by chemical agents occurs readily in most instances. Since these reactions are well known, a detailed discussion will not be given here, but certain points of especial interest will be covered.

Sodium and alcohol, or sodium amalgam, will reduce practically all of these compounds; zinc and acetic acid or the zinc-copper couple will bring about the reduction of unsaturated aldehydes and ketones, acetylenic acids, and unsat-





keto acids and dicarboxylic acids. The fact that succinic and maleic acids do not form a reversible oxidation-reduction system is attributed to the practical irreversibility of the ketonization step. Conant and his coworkers (63,65,65a) were able, however, to determine the apparent reduction potential of a series of unsaturated acids and ketones, and showed that the reduction of these substances is dependent on the potential of the reducing agent, and not on the specific chemical properties thereof.

With  $\alpha,\beta$ -unsaturated ketones there is a strong tendency for dimeric reduction products to be formed, especially with aluminum amalgam and soluble reducing agents. The mechanism of this reaction is probably similar to that postulated earlier for the dimeric reduction of certain arylolefins; that is, the molecule acquires but one electron instead of two from the reducing agent, and the free radical so formed stabilizes itself by dimerization. Two free radicals are possible: one with the odd electron attached to the carbon atom of the carbonyl group, the other with it attached to the terminal carbon atom of the  $C=C-C=O$  chain; in the case of  $\alpha,\beta$ -unsaturated ketones the latter seems to be the one usually formed, whereas with certain unsaturated aldehydes dimerization occurs through the carbon of the carbonyl group (65).

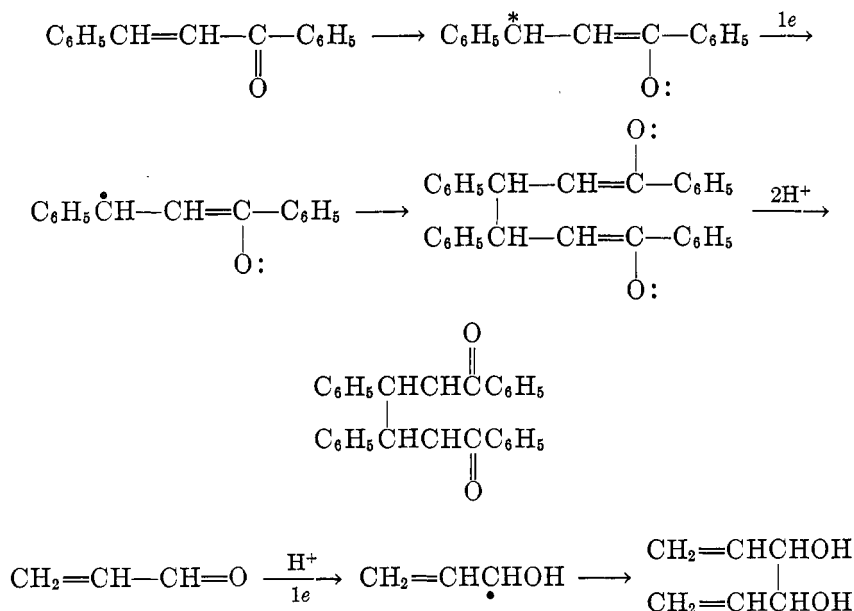

Since  $\alpha,\beta$ -unsaturated aldehydes and ketones, unlike maleic acid and unsaturated keto acids which contain the system  $O=C-C=C-C=O$ , are only reduced by soluble reducing salts (vanadous chloride, chromous chloride, etc.) in acid solution, and the ease of the reduction is a function of the hydrogen-ion concentration, Conant and Cutter (65) have postulated that the compounds themselves are incapable of acquiring an electron from the reducing salt (although they can from a metal surface), but that they form a halochromic salt in the acid solution, which is capable of acquiring electrons from the reducing agent.

*I. Reduction of polyene acids, aldehydes, and ketones*

Since in these molecules the ethylenic bond is activated by conjugation with a carbonyl group and also with another ethylenic group, reduction by chemical means is very easy, and these substances may be reduced by aluminum amalgam as well as by the stronger reducing agents. Because the compounds are, with few exceptions, unsymmetrical, the course of the reduction is complex. The picture is further complicated by the fact that the products of partial reduction may be rearranged into one another by heat and base, and analytical methods are in many cases tedious and inexact. It is not surprising, therefore, that discrepancies exist in the literature as to the course of reduction.

If the theory first proposed by Burton and Ingold (54) is applied to a compound containing the group  $\text{RC}=\text{C}-\text{C}=\text{C}-\text{C}=\text{O}$ , and the assumption is made that the reaction is initiated at the oxygen atom, then, when addition of one hydrogen ion and two electrons has occurred, two intermediate ions are possible:

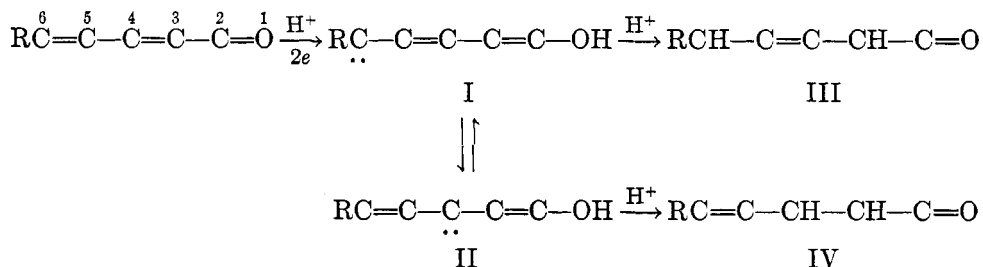

The proportions of the products III and IV, formed by addition of a second hydrogen ion and ketonization, will depend on the way the tautomerism between the ions I and II is displaced, which will, in turn, depend on the nature of the substituents and on the experimental conditions.

If R is an electron-attracting group, and there are no other such groups in the system, then ion I should be the more stable, and the dihydro product should have structure III. This is experimentally true: cinnamalacetic acid ( $\text{R}=\text{C}_6\text{H}_5$ ) (19, 54, 257), cinnamalmalonic acid (19, 54), and similar compounds are all reduced by chemical reducing agents to the  $\beta, \gamma$ -unsaturated acids. Muconic acid ( $\text{R}=\text{COOH}$ ) is also reduced to the  $\beta, \gamma$ -unsaturated acid (54, 86), but here probably the reaction involves addition of hydrogen to the two carbonyl groups at the ends of the conjugated chain.

When R is alkyl or hydrogen, a mixture of dihydro products is usually obtained. The relative amounts of forms III and IV depend on the other substituents. In the case of  $\beta$ -phenylsorbic acid,  $\text{CH}_3\text{CH}=\text{CHC}(\text{C}_6\text{H}_5)=\text{CHCOOH}$ , it might be expected that ion II would predominate, owing to the electron-attracting nature of the phenyl group, and that, therefore, the dihydro product would have structure IV. Kuhn and Hoffer (175), however, found that about 70 per cent of terminal addition occurred with sodium amalgam, and that only about 30 per cent of the  $\gamma, \delta$ -unsaturated acid was obtained. Both of the dihydro acids are stable under the conditions used. The preponderance of form III over form IV may possibly be due to the tendency of the double bond to

become conjugated with the phenyl group. In the case of vinylacrylic acid, where  $R = H$  and there are no other directing substituents, reduction by sodium amalgam in sodium carbonate solution leads to terminal addition of hydrogen (formula III) (54, 297), but in acetic acid solution there is a substantial amount (18 per cent) of the  $\gamma, \delta$ -unsaturated acid formed (54).

Sorbic acid,  $CH_3CH=CH-CH=CH-COOH$ , has been shown by many workers (54, 86, 116) to give nearly a 50-50 mixture of the  $\beta, \gamma$ - and  $\gamma, \delta$ -hexenoic acids when reduced with sodium or aluminum amalgams; the pH of the solution causes a slight variation in the relative amounts. The methylsorbic acids likewise give both forms III and IV (54), although in earlier work (18, 257) the reduction was reported to occur terminally only. With vinylogs of sorbic acid, however, Kuhn and Hoffer obtained only terminal reduction with sodium amalgam (174).

In the diene acids where the carboxyl group is in the middle of the chain, a crossed conjugated system is present. It might be expected that the doubly conjugated ethylene group would be the one attacked, and from the limited number of cases studied, this would seem to be true.  $\alpha$ -Vinylcinnamic acid (V) is reduced by sodium amalgam, in neutral solution, to  $\alpha$ -vinylhydrocinnamic acid (VI), which rearranges to the conjugated isomer (VII) in the presence of base (136). Kuhn (173) originally considered that VII was the primary reaction product.

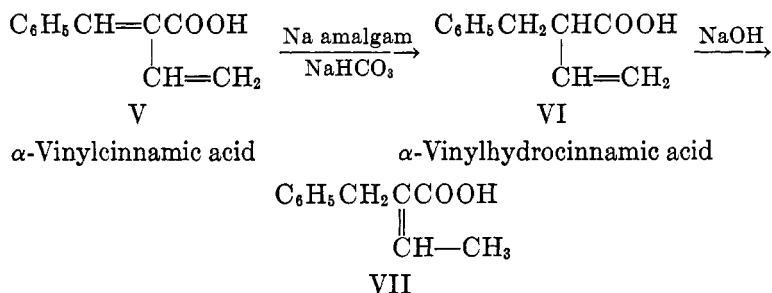

$\alpha$ -Styrylcinnamic acid (VIII) is also reduced at the  $\alpha, \beta$ -double bond by sodium amalgam (136, 290); the product (IX) in this case is stable, since the remaining double bond is conjugated to a phenyl group.

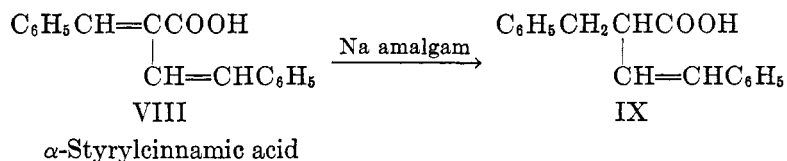

With the 2,3-dicarboxylic acid derivatives of butadiene, reduction by sodium amalgam leads to the saturated acids (290). Thus, 1,4-diphenylbutadiene-2,3-dicarboxylic acid yields a mixture of the meso and *dl* forms of the butane diacids, in which the former predominates.

Very little work has been reported on the reduction of diene ketones and aldehydes. Evans and Farmer (86) found that crotylideneacetone,  $\text{CH}_3\text{CH}=\text{CH}-\text{CH}=\text{CHCOCH}_3$ , is reduced to a dimolecular compound by aluminum amalgam. Fischer and Wiedmann (107) obtained reduction of the ethylene double bond adjacent to the carbonyl group in crotylideneacetone and cinnamalacetone by fermenting yeasts. The reduction of sorbic aldehyde and its vinylog,  $\text{CH}_3\text{CH}=\text{CH}-\text{CH}=\text{CH}-\text{CH}=\text{CH}-\text{CHO}$ , by yeasts led to saturation of the  $\alpha,\beta$ -double bond, and conversion of the aldehyde group to a primary alcohol.

Table 12 contains a summary of the work reported in this field.

### III. ELECTROLYTIC REDUCTION

#### A. Introduction

In the electrolytic reduction of organic compounds there are many variables to be considered; therefore the results are not as susceptible to generalization as are those of chemical reduction and catalytic hydrogenation. The hydrogen overvoltage of the cathode material, the cathodic potential and current density, the hydrogen-ion concentration of the medium, the purity and history of the cathode material, and the presence or absence of various inhibitors and promoters all affect the results. These subjects have been thoroughly discussed in recent reviews (114, 294) and books (51, 113), and are beyond the scope of this article.

The cathodes used may be divided into two large classes: (1) *Those of low overvoltage*: In this class belong cathodes of iron, nickel, platinum, and palladium. These cathodes are rarely effective if used smooth; it is generally necessary to coat them with a deposit of the finely divided metal (242) or to add to the solution a nickel or palladium salt (108). When so treated they bring about the reduction of many substances, and the course of the reaction resembles that taken by catalytic hydrogenation (332). (2) *Those of high overvoltage*: In this class belong cathodes of copper, lead, mercury, zinc, tin, and cadmium. These cathodes may be used in the form of the smooth metal, or the surface may be roughened by alternate reduction and oxidation, or it may be amalgamated with mercury. The presence of small traces of more noble metals in these cathodes lowers the overvoltage considerably, and thereby destroys or diminishes the effectiveness of the cathode (182, 210, 295). Reductions brought about by the cathodes of this class resemble reductions by chemical agents, especially sodium amalgam (182, 210, 332). Sometimes the electrodes of class 1 can be made to resemble those of class 2 by adding to the electrolyte a small amount of certain metal salts, especially those of titanium, chromium, vanadium, iron, and cerium (113), in which case probably the reduced form of the salt is the true reducing agent.

There have been several theories proposed to account for reduction at the cathodes of class 2 (see 332); it has been suggested that nascent hydrogen atoms constitute the active reducing agent, or that hydrogen gas, liberated below the normal potential for hydrogen evolution, reacts with the unsaturated compound.

TABLE 12  
Reduction of diene acids, aldehydes, and ketones by chemical reducing agents

COMPOUND REDUCED	REDUCING AGENTS AND CONDITIONS	DIHYDRO COMPOUNDS FORMED	REFERENCES
Vinylacrylic acid..... $\begin{array}{c} 4 & 3 & 2 & 1 \\ \text{CH}_2 & = & \text{CHCH} & = & \text{CHCOOH} \end{array}$	Na amalgam, NaHCO <sub>3</sub> solution	100% 1,4-	(116, 54, 297)
Sorbic acid..... $\begin{array}{c} 4 & 3 & 2 & 1 \\ \text{CH}_3\text{CH} & = & \text{CHCH} & = & \text{CHCOOH} \end{array}$	Na amalgam, NaHCO <sub>3</sub> solution Na amalgam, acetic acid Na amalgam, neutral or acid solution	80% 1,4- 82% 1,4-; 18% 1,2- Mixture of 1,2- and 1,4-	(145) (54) (116, 86)
$\begin{array}{c} 4 & 3 & 2 & 1 \\ \text{CH}_3\text{CH} & = & \text{CHCH} & = & \text{CHCOOH} \end{array}$	Na amalgam, neutral Na amalgam, NaHCO <sub>3</sub> solution Na amalgam, acetic acid Al amalgam, neutral or alkaline solution Al amalgam, neutral or alkaline solution	40% 1,2-; 60% 1,4- 40% 1,2-; 60% 1,4- 55% 1,2-; 45% 1,4- 30-40% 1,2-; 70-60% 1,4-	(175) (54, 332) (54, 332) (116)
$\begin{array}{c} 4 & 3 & 2 & 1 \\ \text{CH}_2\text{CH} & = & \text{CHCH} & = & \text{C(O)OH} \\ & & & &   \\ & & & & \text{CH}_3 \end{array}$	Devarda's alloy, NaOH Na amalgam, weakly acid	45% 1,2-; 55% 1,4-	(143)
$\begin{array}{c} 4 & 3 & 2 & 1 \\ \text{CH}_2\text{CH} & = & \text{CHCH} & = & \text{C(O)OH} \\ & & & &   \\ & & & & \text{C}_2\text{H}_5 \end{array}$	Na amalgam, weakly acid	41% 1,2-; 59% 1,4- 1,4-Reduction	(332) (18, 19)
$\begin{array}{c} 4 & 3 & 2 & 1 \\ \text{CH}_3\text{CH} & = & \text{CHCH} & = & \text{CHCOOH} \\ & & & &   \\ & & & & \text{C}_2\text{H}_5 \end{array}$	Na amalgam, NaHCO <sub>3</sub> solution Na amalgam, weakly acid	28% 1,2-; 72% 1,4- 1,4-	(54) (19)

<p><math>\gamma</math>-Methylsorbic acid.....</p> $\begin{array}{c} 4 \quad 3 \quad 2 \quad 1 \\ \text{CH}_3\text{CH}=\text{CCH}=\text{CHCOOH} \\   \\ \text{CH}_3 \end{array}$	Na amalgam, weakly acid	1,4-	(18, 19)
<p><math>\beta</math>,<math>\delta</math>-Dimethylsorbic acid.....</p> $\begin{array}{c} 4 \quad 3 \quad 2 \quad 1 \\ \text{CH}_3\text{C}=\text{CHC}=\text{CHCOOH} \\   \quad   \\ \text{CH}_3 \quad \text{CH}_3 \end{array}$	Na amalgam, acid or alkaline	1,4-	(18, 19)
<p>Crotylidene malonic ester.....</p> $\begin{array}{c} 4 \quad 3 \quad 2 \quad 1 \\ \text{CH}_3\text{CH}=\text{CHC}=\text{C}(\text{COOC}_2\text{H}_5)_2 \\   \quad   \\ \text{CH}_3 \quad \text{CH}_3 \end{array}$	Na amalgam, NaHCO <sub>3</sub> solution	1,4-	(257, 258)
<p>Cyanosorbic ester.....</p> $\begin{array}{c} 4 \quad 3 \quad 2 \quad 1 \\ \text{CH}_3\text{CH}=\text{CHCH}=\text{CCOOC}_2\text{H}_5 \\   \\ \text{CN} \end{array}$	Na amalgam, NaHCO <sub>3</sub> solution	38% 1,2-; 62% 1,4- Dimolecular	(54) (62)
<p>Octatrienoic acid.....</p> $\begin{array}{c} 6 \quad 5 \quad 4 \quad 3 \quad 2 \quad 1 \\ \text{CH}_3\text{CH}=\text{CHCH}=\text{CHCH}=\text{CHCOOH} \end{array}$	Al amalgam, neutral	Dimolecular	(62)
<p>Decatetraenoic acid.....</p> $\begin{array}{c} 10 \quad 9 \quad 8 \quad 7 \quad 6 \quad 5 \quad 4 \quad 3 \quad 2 \quad 1 \\ \text{CH}_3\text{CH}=\text{CHCH}=\text{CHCH}=\text{CHCH}=\text{CHCOOH} \end{array}$	Na amalgam, NaHCO <sub>3</sub> solution	1,6-	(174)
<p>Cinnamylideneacetic acid.....</p> $\begin{array}{c} 4 \quad 3 \quad 2 \quad 1 \\ \text{C}_6\text{H}_5\text{CH}=\text{CHCH}=\text{CHCOOH} \end{array}$	Na amalgam, NaHCO <sub>3</sub> solution	1,8-	(174)
<p><math>\alpha</math>-Vinylcinnamic acid.....</p> $\begin{array}{c} 1 \quad 2 \quad 3 \quad 4 \\ \text{C}_6\text{H}_5\text{CH}=\text{CCH}=\text{CH}_2 \\   \\ \text{COOH} \end{array}$	Na amalgam, neutral solution	1,4- 1,2- chiefly 1,2- chiefly	(257) (18, 19) (150) (136)
<p><math>\alpha</math>-Styrylcinnamic acid.....</p> $\begin{array}{c} 1 \quad 2 \quad 3 \quad 4 \\ \text{C}_6\text{H}_5\text{CH}=\text{CCH}=\text{CHC}_6\text{H}_5 \\   \\ \text{COOH} \end{array}$	Na amalgam, NaHCO <sub>3</sub> or acetic acid solution	1,4- (rearrangement)	(173)
<p>.....</p>	Al amalgam, neutral	1,2- chiefly	(136)
<p>.....</p>	Na amalgam, Na <sub>2</sub> CO <sub>3</sub> solution	1,2-	(136)
<p>.....</p>	Na amalgam, acetic acid	1,2-	(136, 290)

TABLE 12—Concluded

COMPOUND REDUCED	REDUCING AGENTS AND CONDITIONS	DIHYDRO COMPOUNDS FORMED	REFERENCES
$\beta$ -Phenylisorbic acid..... $\begin{array}{cccc} & & 1 & \\ & &   & \\ & & \text{C}_6\text{H}_5 & \\ & &   & \\ 4 & 3 & 2 & 1 \\ \text{CH}_3\text{CH}=\text{CH}-\text{C}=\text{CHCOOH} & & & \end{array}$	Na amalgam, neutral solution	30% 1,2-; 70% 1,4-	(175)
$\alpha$ -Phenylcinnamylideneacetic acid..... $\begin{array}{cccc} & & 1 & \\ & &   & \\ & & \text{C}_6\text{H}_5 & \\ & &   & \\ 4 & 3 & 2 & 1 \\ \text{C}_6\text{H}_5\text{CH}=\text{CHCH}=\text{CCOOH} & & & \end{array}$	Na amalgam, neutral solution	1,4-	(257)
Muconic acid..... $\begin{array}{cccc} 1 & 2 & 3 & 4 \\ \text{HOOCCH}=\text{CHCH}=\text{CHCOOH} & & & \end{array}$	Na amalgam	1,4- entirely. The <i>trans-trans</i> gives the <i>trans</i> 1,4-; the <i>cis-cis</i> gives the <i>cis</i> 1,4-dihydro acid	(93)
Ethyl muconate..... $\begin{array}{cccc} 1 & 2 & 3 & 4 \\ \text{HOOCCH}=\text{CHCH}=\text{CHCOOEt} & & & \end{array}$	Al amalgam, neutral, acid, or basic solution	1,4- entirely	(86)
2,3-Diphenylmuconic acid..... $\begin{array}{cccc} 1 & 2 & 3 & 4 \\ \text{HOOCCH}=\text{C}-\text{C}=\text{CHCOOH} \\   \quad   \\ \text{C}_6\text{H}_5 \quad \text{C}_6\text{H}_5 \end{array}$	Na amalgam, weakly basic	1,4- entirely	(93)
2,3-Dicarboxy-1,4-diphenylbutadiene..... $\begin{array}{cccc} 1 & 2 & 3 & 4 \\ \text{C}_6\text{H}_5\text{CH}=\text{C}-\text{C}=\text{CHC}_6\text{H}_5 \\   \quad   \\ \text{HOOC} \quad \text{COOH} \end{array}$	Na amalgam, NaHCO <sub>3</sub> solution	No dihydro; mixture of meso (chiefly) and some <i>dl</i> saturated acid	(290)
2,3-Dicarboxy-1,1,4-triphenylbutadiene..... $\begin{array}{cccc} 1 & 2 & 3 & 4 \\ (\text{C}_6\text{H}_5)_2\text{C}=\text{C}-\text{C}=\text{CHC}_6\text{H}_5 \\   \quad   \\ \text{HOOC} \quad \text{COOH} \end{array}$	Na amalgam, NaHCO <sub>3</sub> solution	No dihydro; 80% <i>dl</i> , 20% meso saturated	(290)
Crotylideneacetone..... $\begin{array}{cccc} 4 & 3 & 2 & 1 \\ \text{CH}_3\text{CH}=\text{CHCH}=\text{CHCOCH}_3 \end{array}$	Al amalgam, neutral solution Yeast, neutral	80% dimolecular 1,2-Dihydro	(86) (107)





Because of the close resemblance between the electrolytic reduction of sorbic acid by the cathodes of this class, and the chemical reduction of sorbic acid by sodium and aluminum amalgams, Wilson (332) has suggested that the two processes have the same mechanism, and has postulated that the mechanism used by Burton and Ingold (54) to explain reduction by dissolving metals can also be applied to electrolytic reduction at high-overvoltage cathodes (see section II B).

Electrolytic reduction at the cathodes of class 1 is probably a catalytic reaction; the hydrogen liberated at the cathode surface adds to the unsaturated compound under the catalytic influence of the finely divided metal surface (332).

### *B. Reduction of unsaturated hydrocarbons*

Practically no work has been reported on the electrolytic reduction of ethylenic hydrocarbons, but several unsaturated acids have been studied in which the double bond is sufficiently far removed from the carboxyl group so that there is little influence of one group on the other. In view of the analogies presented above, such acids should not be reduced at the high-overvoltage cathodes, but should be saturated at cathodes of spongy nickel or platinum. These predictions are realized: linoleic, undecylenic, allylacetic, and allylmalonic acids are reduced to the saturated acids at a nickel cathode covered with spongy nickel (242), and oleic acid has been reduced to stearic acid at a spongy-nickel cathode (242) and at a platinized cathode (210), but it is not attacked when cathodes of lead, mercury, or copper are used (198, 332).

Acetylenes are reduced electrolytically at the cathodes of class 1, and the course of the reaction is very similar to that of catalytic hydrogenation. Acetylene itself is reduced at a platinized-platinum cathode, in acid or basic medium, to a mixture of ethylene and ethane. By adjusting the current density the reaction can be controlled to give ethylene alone; at higher current densities the reduction is more vigorous, and ethane is formed (36). Dialkylacetylenes are reduced at a spongy-nickel cathode, to the *cis* olefins (61); these are also the products formed when the dialkylacetylenes are hydrogenated catalytically in the presence of Raney nickel (56). It might be expected that the dialkylacetylenes, which can be reduced by sodium in liquid ammonia (but not by sodium and alcohol) (56), would be reduced electrolytically at the cathodes of class 2, but even with amalgamated lead the potential is not sufficiently high, and no reduction occurs (61). Dimethylethynylcarbinol is reduced to the olefinic carbinol, however, in high yields at a copper cathode, and this process is said to have been used in Russia on a semi-commercial scale (100, 101); similarly, methylcyclopropylethynylcarbinol is reduced at a copper cathode to give a 60 to 70 per cent yield of the olefin (118, 119). Monovinylacetylene is reduced to butadiene in good yields at a platinum black electrode (192).

The polynuclear hydrocarbons, which can be reduced both catalytically and by dissolving metals, should be capable of reduction at cathodes of either class. From the limited data available, this would seem to be the case. Anthracene is converted to 9,10-dihydroanthracene at a mercury cathode in alkaline solution,

just as it is by sodium and aluminum amalgams (332). Phenanthrene is reduced in acid solution at a spongy-palladium cathode to the same tetrahydro derivative that is obtained by catalytic hydrogenation over palladium black (49).

*C. Reduction of unsaturated acids, aldehydes, and ketones*

$\alpha,\beta$ -Unsaturated acids are comparatively easily reduced to the saturated acids by electrodes of either class; usually a platinized-platinum or a spongy-nickel cathode is used in acid solution (108, 242), and a mercury cathode in alkaline solution (242); with cinnamic acid a tin or lead cathode is also effective (217, 218). Ordinarily the saturated acid is the only product, but occasionally the carboxylic acid group is attacked. Thus, cinnamic acid at a lead dioxide cathode forms hydrocinnamyl alcohol and a dimeric product, indicating the intermediate formation of an aldehyde (138).

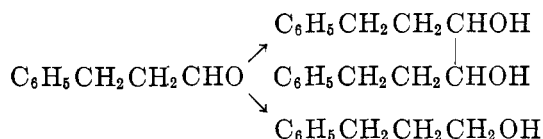
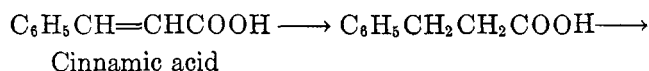

The reduction of benzoic acid at a mercury or lead cathode is of considerable interest, and shows a close resemblance to the reduction of this acid by sodium amalgam. In alkaline solution, at these cathodes, nuclear reduction occurs, and tetrahydrobenzoic acid is obtained; sodium amalgam in alkaline solution produces the same result (210). If the electrolytic reduction is carried out in acid solution, the carboxyl group is attacked, and benzyl alcohol is obtained in high yield (69); sodium amalgam in acid solution is reported to give benzyl alcohol also (see 210).

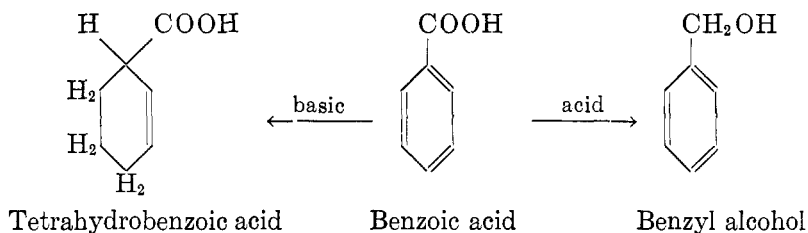

With unsaturated aldehydes and ketones, electrolytic reduction is usually accomplished at a lead or copper cathode. In acid solution, at a lead cathode, organometallic compounds may be formed; this does not occur in neutral or alkaline solution (182), or with electrodes of copper, tin, zinc, or amalgamated lead. Reduction at these cathodes resembles reduction by sodium and by sodium amalgam. Thus, the reaction does not always stop at the saturated carbonyl compound, but may proceed further, to give the saturated alcohol, or dimerization may occur.

Crotonaldehyde and cinnamaldehyde are reduced at a lead cathode to the saturated alcohol (182), but with mesityl oxide a variety of compounds is formed, including desoxymesityl oxide, which probably arises from a dimeric, pinacol-type reduction:

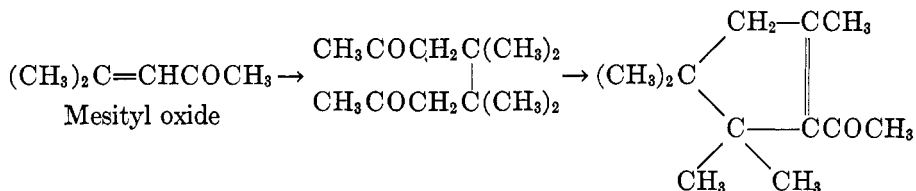

#### Diene acids

The striking analogies between electrolytic reduction on the one hand, and reduction by dissolving metals or by catalytic methods on the other, have been brought out by Wilson (332) and Isaacs and Wilson (143, 144, 145) from a study of the reduction of the butadiene acids, especially sorbic acid. This acid is reduced by sodium amalgam, aluminum amalgam, or Devarda's alloy, to a mixture of the 1,2- and 1,4-dihydrosorbic acids (I and II); it is not reduced by magnesium or iron. Electrolytically, it is attacked at a mercury, cadmium, copper, or tin cathode, and the products are again mixtures of the 1,2- and 1,4-dihydro acids. As table 13 shows, the analogy is close, and the composition of the product is independent of the reducing agent; this argues for a common mechanism for the electrolytic and chemical reduction processes.

Catalytically, with the Adams catalyst, sorbic acid absorbs 1 mole of hydrogen to give a mixture of the completely saturated acid, unreduced sorbic acid, and some of the 3,4-dihydro compound (III); a similar mixture is obtained when sorbic acid is reduced at cathodes of class 1, that is, at a platinized-platinum cathode. The parallel is not so close between reduction at a spongy-nickel cathode and catalytic hydrogenation with Raney nickel (see table 14).

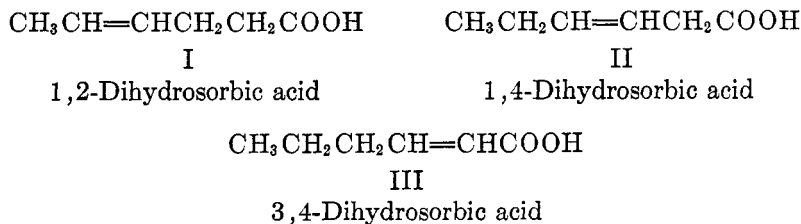

Vinylacrylic acid on reduction with sodium amalgam yields the 1,4-dihydro compound as the principal product; this also predominates when the acid is reduced electrolytically at a copper or mercury cathode in alkaline solution (145). When reduced catalytically, vinylacrylic acid gives a mixture of the 3,4-dihydro and the tetrahydro acids (221); at a spongy-nickel electrode Isaacs and Wilson

report it to give the 3,4-dihydro and tetrahydro acids (145), although Muskat and Knapp (222) had considered the main product to be the 1,2-dihydro derivative.

## IV. CATALYTIC HYDROGENATION

*A. Introduction*

Hydrogen can be added in the presence of a catalyst to practically any carbon-carbon multiple bond. Since the ease of addition varies widely with the position of the unsaturation and with the nature of the adjacent groups, selective hydro-

TABLE 13  
*Reduction of sorbic acid at high-overvoltage cathodes (332)*

REDUCING AGENT	PER CENT OF 1,2-REDUCTION IN		
	NaOH	NaHCO <sub>3</sub>	CH <sub>3</sub> COOH
Mercury cathode.....	40	41	54
Cadmium cathode.....	39	40	54
Copper cathode.....	40		50
Sodium amalgam.....		40	55
Aluminum amalgam.....	45	45	
Devarda's alloy.....	41		

TABLE 14  
*Reduction of sorbic acid at low-overvoltage cathodes (332)*

REDUCING AGENT	MEDIUM	PER CENT 3,4- DIHYDRO	PER CENT 1,2- + 1,4- DIHYDRO	PER CENT SATURATED ACID
Spongy-nickel cathode.....	70% acetic acid	19	18	63
Platinized-platinum cathode.....	70% acetic acid	46	5	49
H <sub>2</sub> + Raney nickel.....	Alcohol	86	10	3
H <sub>2</sub> + Adams catalyst.....	Alcohol	38	7	55

genation of one unsaturated group and not another can frequently be attained by a suitable choice of catalyst and conditions.

A great number of hydrogenation catalysts have been developed, and it is beyond the scope of this article to discuss them in detail. For a comprehensive review of hydrogenation catalysts and their preparation, the reader is referred to the texts of Ellis (84) and of Berkman, Morrell, and Egloff (34). The ease of hydrogenation, and sometimes the course of this reaction, may vary, not only with different catalytic metals, but also with different methods of preparing a given metal catalyst; consequently for laboratory use those catalysts are most satisfactory the preparation of which is simplest and gives on repetition material of uniform and reproducible activity. For this reason the Adams platinum and palladium oxide-black catalysts (162), the Raney nickel catalyst (67, 219a),

and certain forms of reduced nickel and copper chromite catalysts (4) are of more value, in general, than are the platinum black catalyst of Willstätter (331), the various forms of colloidal platinum and palladium (41, 232, 284, 287), and many of the mixed nickel oxide catalysts.

Because the activity of many catalysts is greatly affected by small traces of impurities, acting as promoters or poisons, and varies from batch to batch, there are many discrepancies between the results of different workers, and a certain amount of caution must be exercised in evaluating literature data. Furthermore, many catalysts age on standing (95, 321) or show varying amounts of fatigue in a reaction (309), so that they no longer give the same results as when fresh, and this has also been a fruitful source of contradictions.

Solvents play an important rôle in determining the ease with which a given substance undergoes hydrogenation (4, 142, 271), and, of course, so do temperature and pressure. The effect of these various experimental conditions, the commercial applications of catalytic hydrogenation, and the various theories have been adequately discussed in recent reviews and texts (4, 34, 84, 270, 326, 274a) and will not be considered here in detail.

### *B. Hydrogenation of olefins*

In the case of olefins, hydrogenation can be brought about by a wide variety of catalysts and under many experimental conditions. Palladium and platinum catalysts, either as finely divided metals or in the colloidal state, and Raney nickel, will bring about the saturation of most olefins at room temperature and at pressures varying from below atmospheric to 2–3 atm. Reduced nickel catalysts can be used at higher temperatures, either in the Sabatier–Senderens technique or under elevated pressures. Copper and cobalt catalysts have been used, although they are less active than nickel and require higher temperatures and pressures. Copper chromite will catalyze the reduction of olefins but is, in general, less effective than nickel or other catalysts (4). Amorphous chromium oxide is also effective, but not the oxides of zinc, manganese, or magnesium (308). Since in the reduction of olefins, high temperatures and pressures may bring about cracking, polymerization, or other side reactions, if it is desired simply to hydrogenate the substance, the platinum, palladium, and active nickel catalysts, which are effective at pressures of 2 to 3 atm., are the ones of choice. Occasionally even these pressures are too high,—as with olefinic carbinols, which may undergo cleavage,—and then the reaction can be carried out at reduced pressures (85, 125).

In contrast to chemical methods, simple olefins are usually hydrogenated catalytically more easily than are conjugated olefins or  $\alpha, \beta$ -unsaturated carbonyl compounds (162), and aryl double bonds are the most difficult to hydrogenate. The reduction of carvone furnishes a good example of the effect of conjugation. In the presence of platinum black or reduced nickel the isolated double bond is saturated first, whereas with zinc and acetic acid, or sodium and alcohol, the conjugated double bond is reduced first (15).

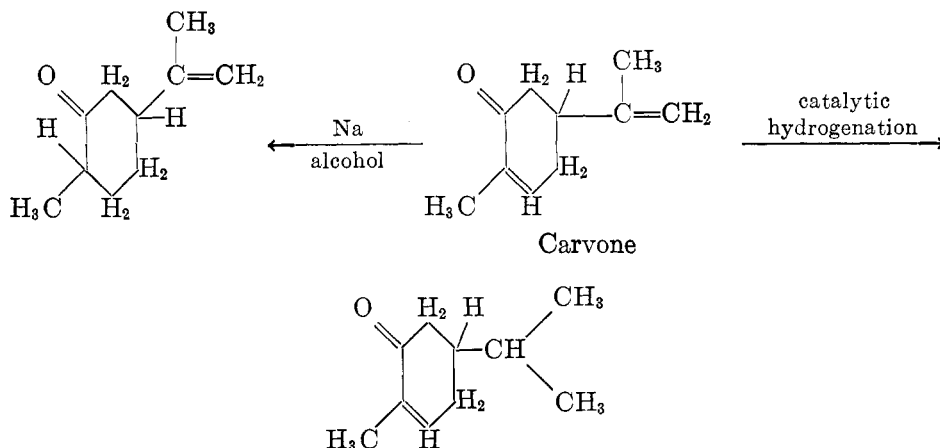

Farmer and Galley (96) observed that the rate of hydrogenation of unsaturated acids increased as the double bond was removed from the carboxyl group (see 129 also). This generalization as to the effect of conjugation does not always hold, however, for in the hydrogenation of citral the conjugated ethylene bond is the first one attacked.

Numerous studies have been made in an effort to determine the effect of structure on the ease of hydrogenation of olefins. Except in a qualitative way, these attempts have not been highly successful, for many other factors contribute to the results, including the weight of the catalyst (309), the solvent (271), the degree of purity of all reagents used, the rate of diffusion of the hydrogen to the catalyst (309), and others. Kailan and Hartel (148) have shown that reproducible rates of hydrogenation cannot be obtained unless all of the conditions are exactly reproduced and samples of catalyst from the same batch are used. In general, a comparison between two compounds, especially if they are very similar in structure, is not reliable unless the hydrogenations are carried out under identical conditions, using the same concentrations, solvents, weights and batch of catalyst, etc. Farkas (91) emphasized this point in saying, "Observed rates of hydrogenation are not comparable unless it is ascertained that the concentrations of the hydrogen and unsaturated compound in the adsorption layer are comparable in the different experiments."

In spite of these difficulties, certain generalizations can be made. Lebedev and his coworkers (186) found that when platinum black is used as the catalyst, monosubstituted olefins,  $RCH=CH_2$  are reduced very rapidly, and the rate is constant or nearly so throughout the reaction. Olefins of the type  $RCH=CHR'$  are reduced more slowly, and the rate declines toward the end. Unsymmetrically disubstituted olefins,  $R_2C=CH_2$ , show a gradual decline in rate. Tri- and tetra-substituted olefins,  $R_2C=CHR'$  and  $R_2C=CR_2$ , are reduced still more slowly, and aryl and carboxyl groups also slow down the rate. Kern, Shriner, and Adams (162) obtained similar results, which are recorded in table 15. Zartman and Adkins (357) also found that arylolefins are hydrogenated more

slowly than aliphatic when nickel-kieselguhr and copper chromite catalysts are used.

Kazanskii and Tatevoysan (159) confirmed the work of Adams as to the deactivating effect of aryl groups when platinum is the catalyst, and reported the following sequence:

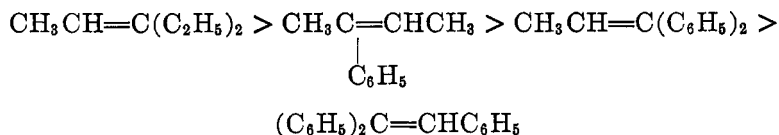

When, however, palladium black is used, aryl groups increase the ease of hydrogenation, and these workers obtained a sequence the exact reverse of the one given above (160). A similar reversal with platinum and palladium has been observed by Yurashevskii (342, 343), who found that with palladium as catalyst, four aryl groups were necessary before a retarding influence was noticed.

TABLE 15  
*Hydrogenation of olefins with platinum black (162)*

OLEFIN	TIME FOR HYDROGENATION
	<i>minutes</i>
Eugenol.....	3.5
Undecylenic acid.....	2.5
Styrene.....	9
1,1-Diphenylethylene.....	21
Stilbene.....	69

Dupont (73) has found that Raney nickel catalyst gives results similar to platinum black as concerns the effect of substitution around the double bond. He obtained the following sequence:

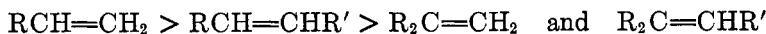

The size and degree of branching of the alkyl groups also has an effect on the rate of hydrogenation. Lagerev (179, 180), in a study of the hydrogenation of isomeric hexenes over platinum black, obtained the following sequences for rates of hydrogenation:

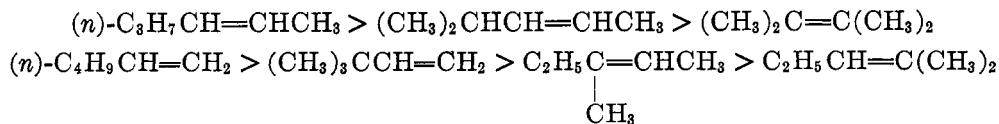

Schuster (275) found that the size of the alkyl group is of great importance; using nickel on activated charcoal as catalyst, he obtained the half-time periods shown in table 16. Schmidt (271), on the other hand, found no particular influence due to the size of the R group in monosubstituted olefins.

In an effort to avoid the difficulties due to poisons, catalyst fatigue, solvents,



and other variables, many workers have attempted to determine the relative ease of hydrogenation of two olefins by studying the distribution of hydrogen between them when a mixture of the two is treated with an insufficient quantity of hydrogen. By using one olefin as a reference compound, a series of relative reactivities can be set up. Vavon (310) and Vavon and Jakes (315, 316), who were among the first to use this technique, used  $\alpha$ -pinene as reference, since the amount of it remaining unreduced could be easily determined by a measurement of the optical rotation. In this way the data in table 17 were obtained. These

TABLE 16  
*Effect of size of alkyl group on rate of hydrogenation*

COMPOUND	HALF-TIME
	<i>minutes</i>
Ethylene.....	8
Propylene.....	104
1-Butene.....	225
2-Methylpropene ("isobutene").....	1100

TABLE 17  
*Hydrogenation of olefins in admixture with  $\alpha$ -pinene (310, 316)*

COMPOUND	PER CENT HYDROGENATED
$(n)C_3H_7CH=CHC_2H_5$ .....	96
$C_2H_5CH=C(CH_3)_2$ .....	71
$CH_3CH=C(C_2H_5)_2$ .....	70
$(CH_3)_2C=CC_2H_5$ .....	65
$\begin{array}{c}   \\ CH_3 \\ C_6H_5CH=CHCOOH \end{array}$ .....	65
$C_6H_5C=CHCOOH$ .....	32
$\begin{array}{c}   \\ CH_3 \\ C_6H_5CH=CCOOH \end{array}$ .....	22
$\begin{array}{c}   \\ CH_3 \\ C_6H_5C=CCOOH \\   \quad   \\ H_3C \quad CH_3 \end{array}$ .....	18

results are in general agreement with those mentioned above with regard to the effect of degree of substitution of the double bond.

In a modification of this type of study, Lebedev (186, 187) found that a mixture of olefins of the same degree of substitution is hydrogenated concurrently, with no break in the curve, whereas if the two olefins are of different degrees of substitution they are hydrogenated consecutively, and there is a break in the curve. By using olefins of known structures as reference substances, it is possible in this way to determine the degree of substitution of an unknown olefin.

Similar results have also been obtained by Farmer and Galley (95, 96). Davis, Thompson, and Crandall (68) have also confirmed Lebedev's work, and have determined by fractionation and analysis the composition of the mixture obtained by adding about 50 per cent of the theoretical amount of hydrogen to the mixture of two olefins. A summary of their data is given in table 18.

Conclusions regarding relative ease of hydrogenation drawn from competitive hydrogenations are not, however, always valid, as Adkins and his students (7) have shown. They found that the results obtained when two substances were hydrogenated individually and in a mixture were not always concordant. For example, a given amount of pinene alone was hydrogenated in 5 min., whereas allyl alcohol required 34 min.; but when one molar equivalent of hydrogen was added to an equimolar mixture of pinene and allyl alcohol, 92 per cent of the alcohol was reduced, and only 8 per cent of the pinene.

The effect of geometrical configuration of the double bond on ease of hydrogenation has received some attention. In a series of carefully conducted experiments, Paal and Schiedewitz (233, 234, 235) have found that *cis*  $\alpha,\beta$ -un-

TABLE 18  
*Hydrogenation of mixtures of olefins over platinum catalyst (68)*

COMPONENTS OF MIXTURE		PER CENT OF EACH HYDROGENATED (USING INSUFFICIENCY OF HYDROGEN)	
I	II	Per cent of I	Per cent of II
Propene	2-Butene	90	20
1-Butene	2-Butene	79	21
"Isobutene"	Trimethylethylene	96	44
Isopropylethylene	Trimethylethylene	93	20

saturated acids are reduced more rapidly than their *trans* isomers, when colloidal palladium-barium sulfate is the catalyst. Similarly, *cis*-stilbene is hydrogenated more rapidly than *trans*-stilbene (234). The greater ease of hydrogenation of the *cis* forms may be due to the fact that the *cis* olefins are more strongly adsorbed on the catalyst than the *trans* (241). The *cis* form is not, however, always hydrogenated more rapidly than its *trans* isomer. Weygand, Werner, and Lanzendorf (322) found that while the *cis* forms of *p,p'*-dimethyl- and *p,p'*-di-butyl-dibenzoylethylenes were hydrogenated more rapidly than the *trans* forms, with the monosubstituted *p*-methyl- and *p*-butyl-dibenzoylethylenes, the *trans* form was hydrogenated the more rapidly.

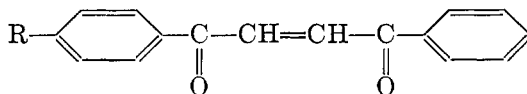

Schuster (275), using a nickel-charcoal catalyst, could observe no difference in the half-time period required for the reduction of the *cis* and *trans* forms of 2-butene. Wessely and Wellaba (320a) found but little difference in the velocity

of hydrogenation of the *cis* and *trans* forms of dimethylstilbene, using palladium sponge as catalyst. Campbell and Kerwin (58) have found that the relative velocity of hydrogenation of the *cis*- and *trans*-4-octenes can be reversed by a change of solvent or catalyst; in ethyl alcohol with Raney nickel the *cis* form was hydrogenated much more rapidly, but when platinum oxide-platinum black was used, the *trans* form was the more rapidly reduced.

In the hydrogenation of olefins under moderate conditions, few side reactions occur. In the case of the higher unsaturated acids some migration of the double bond does take place, however. Hilditch and Vigarthi (129) showed that when  $\Delta^{9,10}$ -octadecenoic ester is reduced at 115°C. with a nickel catalyst, and an insufficiency of hydrogen is used, the unsaturated part of the product contains the *cis* and *trans* forms of the  $\Delta^{8,9}$ -,  $\Delta^{9,10}$ -,  $\Delta^{10,11}$ -ethylenic acids.

Olefinic double bonds can sometimes be hydrogenated without the use of hydrogen gas. Cinnamic acid is reduced to hydrocinnamic acid by treatment with platinum black in boiling tetralin, the solvent being oxidized to naphthalene (164).

### C. Selective hydrogenation

When there are two or more unsaturated groups in a molecule, the question arises as to which of these will be hydrogenated first. The answer, of course, depends on the nature of the two groups, the catalyst used, and the experimental conditions.

The aliphatic ethylene group is so easily hydrogenated that when it is present in a molecule together with an aryl nucleus or a carboxyl or carbalkoxyl group the ethylene bond is almost always hydrogenated first. This is true for aryl-olefins and for olefinic acids and esters with platinum, palladium, Raney nickel, many nickel and nickel oxide catalysts, copper chromite, etc. There are some exceptions. If the aryl nucleus is activated, or if the experimental conditions are strenuous, it may be saturated more or less simultaneously with the ethylene group. Thus Ipatieff (139, page 250) has shown that olefinic phenols are reduced to alkylphenols in the presence of copper oxide at 290°C., but with a nickel catalyst simultaneous saturation of the side chain and of the nucleus occurs. With copper oxide allylbenzene is reduced only in the side chain, but if nickel oxides are used, cyclohexylpropane is obtained (34). Sauer and Adkins (263) have shown that butyl oleate in the presence of zinc chromite at 300°C. undergoes selective saturation of the carboxyl group, yielding octadecenol, but if copper chromite is used, the product is the saturated alcohol. Komari (171a) reported that the ethyl esters of ricinoleic and erucic acids can be reduced to the unsaturated alcohols by an iron-chromium oxide catalyst at 320°C.

With unsaturated aldehydes and ketones, selective hydrogenation of the ethylenic group is more difficult; in many cases, especially with aldehydes, it is not possible, and the product obtained is the saturated alcohol, or even the saturated hydrocarbon (70, 292). In other cases the saturated carbonyl compound is the first product formed, and in still others, the carbonyl group may be attacked first (70). Adams and his coworkers (2, 48, 152, 306) found that the



The selective hydrogenation of an ethylene group conjugated with another will be discussed in section IV E. When there are two ethylene groups in a molecule, and they are not conjugated with each other, it is sometimes possible to obtain a consecutive hydrogenation, and to isolate the intermediate mono-

TABLE 19  
*Selective catalytic hydrogenation of non-conjugated diolefins*

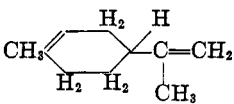
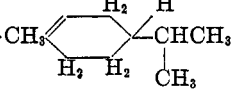
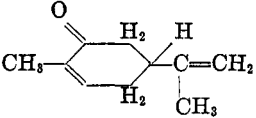
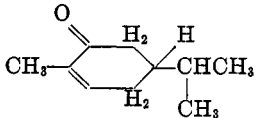
COMPOUND REDUCED	CATALYST	PRIMARY PRODUCT	REFER- ENCE
Limonene..... 	CuO		(139)
	Ni-kieselguhr		(15)
Citral..... $\text{CH}_3\text{C}=\text{CHCH}_2\text{CH}_2\text{C}=\text{CHCHO}$ $\quad \quad \quad   \quad \quad \quad \quad  $ $\quad \quad \quad \text{CH}_3 \quad \quad \quad \text{CH}_3$	Ni-kieselguhr	$\text{CH}_3\text{C}=\text{CHCH}_2\text{CH}_2\text{CH}(\text{CH}_3)\text{CHO}$ $\quad \quad \quad   \quad \quad \quad \quad  $ $\quad \quad \quad \text{CH}_3 \quad \quad \quad \text{CH}_3$	(15)
Geraniol..... $\text{CH}_3\text{C}=\text{CHCH}_2\text{CH}_2\text{C}=\text{CHCH}_2\text{OH}$ $\quad \quad \quad   \quad \quad \quad \quad  $ $\quad \quad \quad \text{CH}_3 \quad \quad \quad \text{CH}_3$	Ni-kieselguhr	$\text{CH}_3\text{C}=\text{CHCH}_2\text{CH}_2\text{CH}(\text{CH}_3)\text{CH}_2\text{CH}_2\text{OH}$ $\quad \quad \quad   \quad \quad \quad \quad  $ $\quad \quad \quad \text{CH}_3 \quad \quad \quad \text{CH}_3$	(15)
Linalool..... $\text{CH}_3\text{C}=\text{CHCH}_2\text{CH}_2\text{C}(\text{OH})\text{CH}=\text{CH}_2$ $\quad \quad \quad   \quad \quad \quad \quad  $ $\quad \quad \quad \text{CH}_3 \quad \quad \quad \text{CH}_3$	Ni-kieselguhr	$\text{CH}_3\text{C}=\text{CHCH}_2\text{CH}_2\text{C}(\text{OH})(\text{CH}_3)\text{CH}_2\text{CH}_3$ $\quad \quad \quad   \quad \quad \quad \quad  $ $\quad \quad \quad \text{CH}_3 \quad \quad \quad \text{CH}_3$	(15)
Carvone..... 	Ni-kieselguhr		(15)
2-Ethyl-6-methyl-1,5-heptadiene.... $(\text{CH}_3)_2\text{C}=\text{CHCH}_2\text{CH}_2\text{C}=\text{CH}_2$ $\quad \quad \quad \quad \quad \quad  $ $\quad \quad \quad \quad \quad \quad \text{C}_2\text{H}_5$	Raney nickel	$(\text{CH}_3)_2\text{C}=\text{CHCH}_2\text{CH}_2\text{CH}(\text{C}_2\text{H}_5)\text{CH}_3$ $\quad \quad \quad \quad \quad \quad  $ $\quad \quad \quad \quad \quad \quad \text{C}_2\text{H}_5$	(76)

olefins. In general, the double bond with the fewer substitutions is hydrogenated first. Some cases of such selective hydrogenation are given in table 19.

#### D. Hydrogenation of acetylenes, and the stereochemical course of hydrogenation

The acetylene bond is readily attacked by hydrogen in the presence of a catalyst, under mild conditions, and a wide variety of catalysts may be used. While very little attention has been paid to the effect of substituents on the ease of hydrogenation of the triple bond, there is some evidence to indicate that an

accumulation of phenyl groups hinders, and may completely inhibit, hydrogenation. Tetraphenylbutyndiol,  $(\text{C}_6\text{H}_5)_2\text{C}(\text{OH})\text{C}\equiv\text{C}(\text{OH})(\text{C}_6\text{H}_5)_2$ , and 1,4-diphenyl-1,4-di- $\alpha$ -naphthylbutyndiol are hydrogenated much more slowly in the presence of colloidal palladium than are purely aliphatic acetylenic glycols of about the same molecular weight (345, 347, 352). Wieland and Kloss (324) found that di(triphenylmethylacetylene),  $(\text{C}_6\text{H}_5)_3\text{C}-\text{C}\equiv\text{C}-\text{C}(\text{C}_6\text{H}_5)_3$  is not attacked by hydrogen in the presence of platinum or palladium catalysts, and that 1,3,3,3-tetraphenyl-1-propyne,  $(\text{C}_6\text{H}_5)_3\text{C}-\text{C}\equiv\text{C}-\text{C}_6\text{H}_5$ , is hydrogenated only very slowly.

Ordinarily, but few side reactions accompany the hydrogenation of acetylenes, especially when the reaction is carried out under mild conditions; occasionally polymerization occurs, and with tertiary acetylenic carbinols some cleavage of the molecule to a ketone may take place (293).

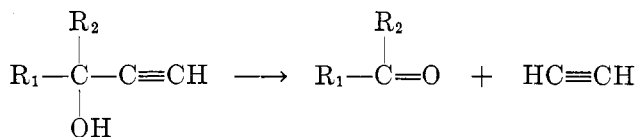

The two points of chief interest in the catalytic hydrogenation of acetylenes are the selectivity of the process, and, in the case of disubstituted acetylenes, the stereochemical course of the reaction. The hydrogenation of acetylene itself has been investigated mainly with a view towards developing a synthesis of ethylene and of liquid hydrocarbons suitable for use as motor fuels.

Acetylene can be reduced to ethylene or ethane in good yields over a variety of catalysts at low temperatures. At higher temperatures, considerable polymerization occurs. Since there is no sharp break in the hydrogenation curve at half-reduction, the relative amounts of ethylene and ethane obtained depend, to a large extent, on the proportions of hydrogen and acetylene used, and to a less extent on the temperature—ethane formation is favored at higher temperatures—and on the catalyst. Platinum catalysts tend to favor the formation of ethane (236, 259, 260), and it is easier to stop at the ethylene stage with palladium and nickel catalysts (1, 106, 219, 254, 259). Pilcher (240) found that at 55°C. with a nickel-molybdenum catalyst ethylene and ethane were produced. Ross, Culbertson, and Parsons (254) found that an 80 per cent yield of ethylene could be obtained by passing a mixture of 47 volume per cent acetylene and 53 volume per cent hydrogen over freshly reduced nickel.

Polymerization, which occurs to some extent even at low temperatures, predominates at higher temperatures, and the main reaction product consists of liquid, petroleum-like hydrocarbons. By suitable regulation of the temperature and the catalyst activity, it is possible to obtain liquid motor fuels of practically any desired boiling range (239, 282).

The course of the hydrogenation of substituted acetylenes depends to a great extent on the nature of the catalyst used, and to a less extent on the nature of the substituents. With platinum black the reaction is non-selective and non-uniform, and cannot be stopped at the olefin stage; at least, it is not possible to

obtain high yields of the olefin in this way, since apparently it starts to undergo hydrogenation almost as soon as it is formed (41, 72, 188, 345, 351, 356). Palladium black likewise does not bring about selective hydrogenation to the olefin (41, 356). With colloidal palladium, on the other hand, reduction is selective in the large majority of cases studied, and when one molar equivalent of hydrogen has been added, the product is largely or entirely the olefin (41, 42, 44, 45, 123, 161, 163, 197, 230, 280, 345, 350, 353). There is, apparently, but one general exception to this rule: Lai (181) was unable to obtain any selective hydrogenation of acetylenic bromides of the type  $RC\equiv CCH_2Br$ , and the triple bond was always saturated.

Bourguel (44) has pointed out that this selectivity is not due to the fact that the acetylenes are always reduced more rapidly than the corresponding olefins, for this is not the case. With monosubstituted acetylenes (44), arylacetylenes (45, 344, 356), acetylenic alcohols (346, 356), and some unsymmetrical acetylenic glycols (356), the olefins add hydrogen as rapidly as (or even more rapidly than) the acetylenes, yet even here the selectivity occurs. This selective action of colloidal palladium is very probably connected with selective adsorption of the acetylene on the catalyst, and little or no olefin can be adsorbed until the acetylene is used up (91). Ott and Schurmann (229) considered that the selectivity was connected with reaction velocity, and believed that those catalysts which gave the highest reaction velocity showed the least selective action; in view of the fact that the velocity of hydrogenation with colloidal palladium can be as great as that with platinum black, this explanation does not seem probable.

Raney nickel catalyst shows a selective action similar to that of colloidal palladium. Dupont (74) and Campbell and O'Connor (59) have shown that mono- and di-substituted acetylenes can be reduced smoothly to the corresponding olefins in the presence of this catalyst. This is also true for tertiary acetylenic carbinols (59). With monosubstituted alkylacetylenes, phenylacetylene, and phenylmethylacetylene there is no sharp break in the hydrogenation curve at the olefin stage, yet the olefin can be isolated in good yield. Dialkyl- and diaryl-acetylenes show a very sharp break in the curve at half-hydrogenation, as do the acetylenic carbinols (59).

Raney iron shows a selectivity more marked than that of Raney nickel, for in the cases of amyl-, hexyl-, and phenyl-acetylenes, and of some dialkylacetylenes, the reduction proceeds to the olefin stage and stops there (238, 302). This catalyst is much less active than Raney nickel and requires higher temperatures and pressures. Colloidal platinum sometimes shows a selective action (325, 344), as do various palladium and nickel-charcoal catalysts (228) and reduced nickel (120, 197).

The stereochemical course of the hydrogenation of disubstituted acetylenes and certain olefins has been of considerable interest because of its connection with the mechanism of catalytic hydrogenation. Early work by Paal (230) and by Kelber and Schwartz (161) indicated that the hydrogenation of such substances as phenylpropionic acid and tolane by hydrogen in the presence of colloidal palladium led to the pure *cis* olefins, whereas reduction by chemical meth-

ods formed the *trans* isomers. Later work, however, of Zalkind and his students on acetylenic glycols (345, 348, 351), of Williams and James (325) on acetylenedicarboxylic acid and tolane, and of Ott and his coworkers (228, 229) on acetylenic acids and tolane, seemed to show that the reaction was not so simple, and that varying mixtures of *cis* and *trans* olefins were produced. Zalkind (345, 346) reported that in the hydrogenation of tetramethylbutyndiol,  $(\text{CH}_3)_2\text{C}(\text{OH})\text{C}\equiv\text{CC}(\text{OH})(\text{CH}_3)_2$ , the more rapid the hydrogenation, the more of the *cis* olefin was formed, and he considered that the amount of catalyst used was important in determining the relative proportions of the *cis* and *trans* isomers formed. Ott and Schroeter (228) endeavored, by using poisoned catalysts, to establish a relationship between the activity of the catalyst and the relative amounts of *cis* and *trans* isomers obtained; although they had difficulty in obtaining reproducible results, they concluded that the more active catalysts gave larger amounts of the *cis* form. In the hydrogenation of tolane over a nickel- or palladium-charcoal catalyst, isostilbene was obtained, but when a cobalt-charcoal catalyst was used, some *trans*-stilbene was formed.

The more recent work of Bourguel (42, 44, 45), of Dupont (74), and of Campbell and Eby (56) on the catalytic hydrogenation of disubstituted acetylenes, and of Farkas and Farkas (89, 90, 91, 92), Greenhalgh and Polanyi (124), and others on the mechanism of catalytic hydrogenation and exchange reactions, has done much to clear up the confusion. Bourguel and his students (42, 44, 123) have shown that the olefin obtained by the hydrogenation of a disubstituted acetylene in the presence of colloidal palladium (on starch) is almost always the *cis* isomer, uncontaminated by any of the *trans* form; they established the configurations of many of the olefins by means of Raman spectra. The only case reported by Bourguel in which any *trans* olefin was obtained was that of 4-phenyl-3-butyne-2-one,  $\text{C}_6\text{H}_5\text{C}\equiv\text{CCOCH}_3$  (42). Other workers (153, 253, 280) have used this method to prepare pure *cis* olefins, and have not reported the formation of any *trans* isomers. Campbell and Eby (56, 57) and Dupont (74) have found that this is true also for Raney nickel catalyst; the *cis* olefins can be obtained easily and in a state of purity by hydrogenating dialkylacetylenes in the presence of Raney nickel. The configurations of many of the olefins so obtained have been established by Raman spectra, dielectric-constant measurements, freezing-point data, etc.

Bourguel (42) has suggested that the *primary* product in any catalytic hydrogenation of a disubstituted acetylene is always the *cis* form of the olefin, and that this might undergo stereochemical conversion to the *trans* form in the presence of the hydrogenation catalyst. Such a conversion would be favored by a relatively slow hydrogenation velocity, and this would serve to explain the results of Zalkind and Ott mentioned above. Bourguel (42) has also pointed out that in those cases where some of the *trans* forms have been obtained by Zalkind and Ott, the *cis* forms of the olefins were relatively unstable and easily converted to their *trans* isomers—this is true of maleic acid, allocinnamic acid, and isostilbene—whereas when purely aliphatic olefins were produced, no *trans* forms were obtained. Aliphatic *cis* olefins are extremely resistant to conversion to the *trans* olefins by the usual means (61, 253).



From studies of the hydrogenation of ethylene and the catalytic exchange reaction between deuterium and ethylene, Farkas and Farkas (90) have proposed that low-temperature catalytic hydrogenation of an unsaturated linkage occurs by the *simultaneous* addition of two hydrogen atoms from the same hydrogen molecule, to the unsaturated bond, in contrast to chemical reduction, which probably occurs by a stepwise mechanism (see section II B). On this basis, catalytic hydrogenation of disubstituted acetylenes should always yield the *cis* olefins, *cis* ethylenic compounds should form the meso saturated derivatives, and *trans* ethylenic compounds the *racemic* saturated compounds, as primary hydrogenation products, whereas chemical reduction should yield the more stable form, *trans* or meso, as the case may be. The *cis* olefin formed from the acetylene could be subsequently converted to the *trans* by a catalytic exchange reaction, and the *racemic* saturated compound to the meso (the more stable form), either by enolization (if a carbonyl group is present) or by racemization. If the hydrogenation occurs rapidly enough, and if the product formed is relatively stable, the primary product would be the one isolated. This explains the non-appearance of any *trans* olefin in the catalytic hydrogenation of dialkylacetylenes over colloidal palladium or Raney nickel. If, on the other hand, the hydrogenation takes place relatively slowly, and the primary product is one which is easily converted to its stereoisomer, then mixtures might be expected; mixtures are found in the hydrogenation of tolane, acetylenedicarboxylic acid, and dimethylfumaric acid over comparatively inactive catalysts (227, 228, 229).

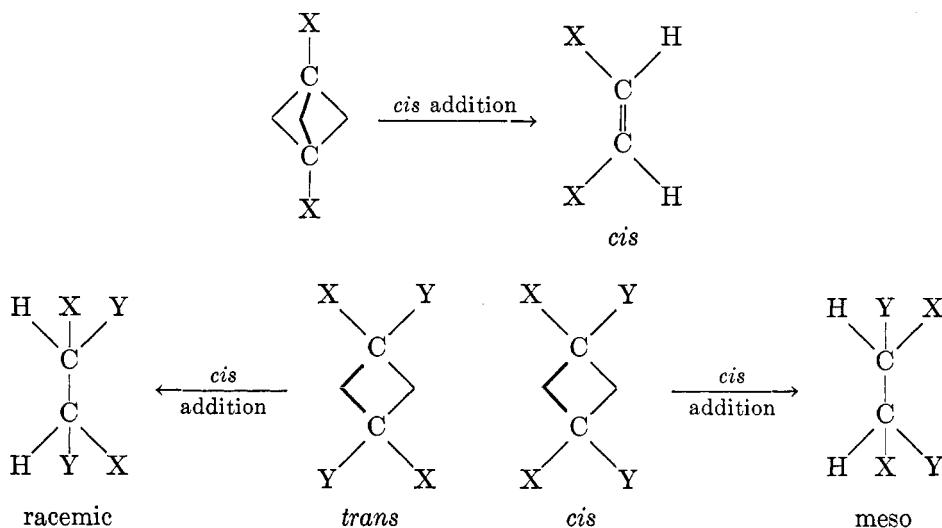



Wessely and Welleba (320a) have recently used catalytic hydrogenation to establish the configurations of diethylstilbestrol and its dimethyl ether. These substances, on treatment with hydrogen in the presence of palladium sponge, gave high yields of the *racemic* saturated derivatives, and therefore must have the *trans* structures.

The data on the stereochemical course of hydrogenation are summarized in table 20.

TABLE 20  
Stereochemical course of hydrogenation of acetylenes and olefins

COMPOUND REDUCED	CATALYST AND CONDITIONS	CONFIGURATION OF PRODUCT	REFER-ENCES
2-Pentyne.....	Pd-starch, room temperature	<i>cis</i>	(280)
	Pd-BaSO <sub>4</sub>	<i>cis</i>	(163)
	Colloidal Pd	<i>cis</i>	(123)
2-Hexyne.....	Colloidal Pd	<i>cis</i>	(123)
	Raney Ni	<i>cis</i>	(57)
3-Hexyne.....	Colloidal Pd	<i>cis</i>	(253)
	Raney Ni	<i>cis</i>	(57)
2-Heptyne.....	Colloidal Pd	<i>cis</i>	(123)
2-Octyne.....	Colloidal Pd	<i>cis</i>	(123)
	Raney Ni	<i>cis</i>	(57, 74)
3-Octyne.....	Raney Ni	<i>cis</i>	(56)
4-Octyne.....	Raney Ni	<i>cis</i>	(56)
5-Decyne.....	Raney Ni	<i>cis</i>	(56)
Tetramethylbutyndiol.....	Raney Fe	<i>cis</i>	(302)
$\begin{array}{c} (\text{CH}_3)_2\text{CC}\equiv\text{CC}(\text{CH}_3)_2 \\   \quad   \\ \text{OH} \quad \text{OH} \end{array}$	Colloidal Pd, homogeneous solution	<i>cis</i>	(42, 147)
	Colloidal Pd in ethyl acetate	Some <i>trans</i>	(42)
	Colloidal Pd	Mixture of <i>cis</i> and <i>trans</i>	(346)
	Pd-charcoal	<i>cis</i>	(228)
	Poisoned catalysts	<i>cis</i> + 30% <i>trans</i>	(228)
1-Phenyl-1-propyne.....	Colloidal Pd	<i>cis</i>	(123)
Diphenylacetylene.....	Colloidal Pd, ethyl acetate	<i>cis</i>	(42)
	Colloidal Pd, acetic acid	<i>cis</i> , trace of <i>trans</i>	(161)
	Ni- or Pd-charcoal	<i>cis</i>	(228)
	Co-charcoal	<i>cis</i> + 8% <i>trans</i>	(228)
<i>o, o'</i> -Dinitrotolane.....	Ni, neutral solution, cold	<i>cis</i> -Diaminostilbene	(256)
Tetraphenylbutyndiol.....	Colloidal Pd	Various mixtures of <i>cis</i> and <i>trans</i>	(345)
$\begin{array}{c} (\text{C}_6\text{H}_5)_2\text{CC}\equiv\text{CC}(\text{C}_6\text{H}_5)_2 \\   \quad   \\ \text{OH} \quad \text{OH} \end{array}$			
1,4-Diphenyl-1,4-di- <i>p</i> -tolylbutyndiol.....	Colloidal Pt	71% <i>cis</i> , 19% <i>trans</i>	(351)
1,4-Diphenyl-1,4-di- $\alpha$ -naphthylbutyndiol.....	Colloidal Pd	96% <i>cis</i> , 4% <i>trans</i>	(352)
3-Phenyl-2-propyn-1-ol.....	Colloidal Pd	<i>cis</i>	(42)
$\text{C}_6\text{H}_5\text{C}\equiv\text{CC}_2\text{H}_4\text{OH}$			
Tetrollic acid.....	Colloidal Pt	63% <i>cis</i> , 4% <i>trans</i>	(325)
$\text{CH}_3\text{C}\equiv\text{CCOOH}$	Colloidal Pd	<i>cis</i>	(42)
Ethylpropionic acid.....	Colloidal Pd	<i>cis</i>	(42)
Propylpropionic acid.....	Colloidal Pd	<i>cis</i>	(42)
Amylpropionic acid.....	Colloidal Pd	<i>cis</i>	(42)

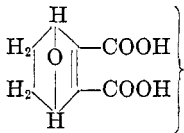
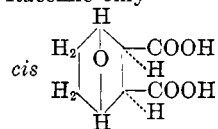
TABLE 20—Continued

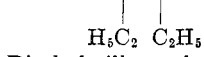
COMPOUND REDUCED	CATALYST AND CONDITIONS	CONFIGURATION OF PRODUCT	REFERENCES
Hexylpropionic acid.....	Colloidal Pd	<i>cis</i>	(42)
Stearic acid.....	Reduced Ni	<i>cis</i> (oleic)	(120)
CH <sub>3</sub> (CH <sub>2</sub> ) <sub>7</sub> C≡C(CH <sub>2</sub> ) <sub>7</sub> COOH			
Behenic acid.....	Reduced Ni	<i>cis</i> (erucic)	(120)
CH <sub>3</sub> (CH <sub>2</sub> ) <sub>7</sub> C≡C(CH <sub>2</sub> ) <sub>11</sub> COOH			
Acetylenedicarboxylic acid.....	Colloidal Pt (K salt)	<i>trans</i>	(325)
	Colloidal Pd	<i>cis</i>	(42)
	Colloidal Pd, poisons	Chiefly <i>cis</i> , some <i>trans</i>	(228)
Phenylpropionic acid.....	Colloidal Pd	<i>cis</i>	(42, 230)
Phenylethynyl methyl ketone.....	Colloidal Pd	Mixture of <i>cis</i> and <i>trans</i>	(42)
C <sub>6</sub> H <sub>5</sub> C≡CCOCH <sub>3</sub>			
<i>cis</i> -Dimethylstilbene.....	Pd-charcoal	90% meso, 10% racemic	(227)
	Pd sponge, acetic acid	99% meso	(320a)
<i>trans</i> -Dimethylstilbene.....	Pd-charcoal	Racemic	(227)
	Pd sponge, acetic acid	98% racemic	(320a)
Dimethylmaleic acid.....	Pd or Ni-charcoal	86% meso, 14% racemic	(227)
Dimethylfumaric acid.....	Pd-charcoal	70% racemic, 30% meso	(227)
	Ni-charcoal	Racemic only	(227)
			(9)
	Pt black		
RO-C <sub>6</sub> H <sub>4</sub> -C≡C-CH <sub>3</sub> .....	Colloidal Pd	<i>cis</i>	(132a)
			
Diethylstilbestrol.....	Pd sponge, acetic acid	88% racemic saturated	(320a)
HOC <sub>6</sub> H <sub>4</sub> C=CC <sub>6</sub> H <sub>4</sub> OH			
	Pd sponge, acetic acid	97% racemic saturated	(320a)

### E. Hydrogenation of conjugated systems

Compounds containing conjugated systems of double bonds are, in general, fairly easily reduced by catalytic methods, and the point of chief interest in connection with this reaction has been to determine the mode of addition of the hydrogen. It was long believed that catalytic hydrogenation of such systems, in contrast to reduction by chemical methods, occurred by direct addition of molecular hydrogen to one or both of the unsaturated linkages, and that 1,4-addition did not take place. More recent work has shown, however, that

hydrogen can be added at the ends of the conjugated system by catalytic methods, and that this is true both for carbon-oxygen and for carbon-carbon conjugations. In the former case, by using compounds which would yield stable enols, it was possible to isolate these, and thus to demonstrate that terminal addition of hydrogen had taken place, to some extent at least.

Kohler and Thompson (170, 170a) found that hydrogenation of  $\beta$ -phenylbenzalacetomesitylene in the presence of palladium-calcium carbonate catalyst yielded 88 per cent of the saturated ketone, and 12 per cent of its enol, which is relatively stable under the conditions used. Hence, 1,4-addition of hydrogen occurred to the extent of at least 12 per cent.

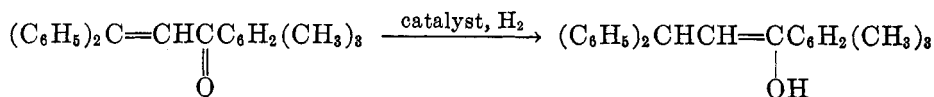

In an analogous manner, using mesityl-substituted unsaturated 1,4-diketones, Lutz and Reveley (203) showed that a large amount of terminal addition of hydrogen occurred, for iodine titration showed the presence of as high as 90 per cent of the dienol in some cases.

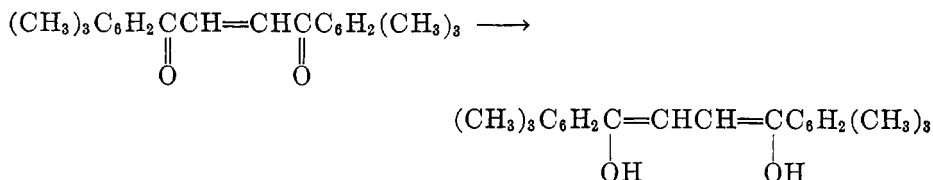

The amount of dienol (and therefore the amount of 1,6-addition of hydrogen) depends to a considerable extent on the temperature and the solvent used in the hydrogenation; at 0°C. more dienol was found than at 30°C., and more 1,6-hydrogenation occurred in ethyl alcohol (94 per cent) than in decalin (17 per cent). The catalytic hydrogenation of benzalacetone under reduced pressure has been shown by Grignard to give at least 22 per cent of the enol, that is, of 1,4-addition (125).

In the hydrogenation of compounds containing carbon-carbon conjugation, there is a strong tendency for both double bonds to be hydrogenated at about the same rate. Hence, at half-hydrogenation the reaction product may contain considerable amounts of unreacted diene and of the fully saturated compound, together with some of the possible dihydro products. Under these conditions, analysis of the mixture is complicated, and it is possible that in many cases the presence of small amounts of dihydro compounds has been overlooked, and that the structures of those found have been misinterpreted. In early work, which was carried out on rather complicated molecules such as cinnamalcamphor and cinnamalmalonic ester, it was reported that at half-hydrogenation no dihydro products were present, but solely an equimolar mixture of the original diene and its saturated derivative (231). More recent work has shown, however, that

stepwise hydrogenation does occur, to some extent, in many cases and that, occasionally at least, terminal addition of hydrogen takes place. The nature of the catalyst is important in determining whether any dihydro compounds will be present at half-hydrogenation; for this purpose platinum catalysts are less satisfactory than Raney nickel (78, 99) or palladium (98). It will be noticed that the catalysts which give the most selective hydrogenation of a conjugated system are the same ones that show greatest selectivity in the hydrogenation of acetylenes to olefins.

Lebedev and Yakubchik (189, 190) found that in the hydrogenation of purely aliphatic diene hydrocarbons over platinum black, dihydro compounds could be isolated at half-reduction. With some types, such as 2,5-dimethyl-2,4-hexadiene,  $(\text{CH}_3)_2\text{C}=\text{CHCH}=\text{C}(\text{CH}_3)_2$ , a definite break occurred in the hydrogenation curve at half-hydrogenation, and when the reaction was stopped at this point, the 1,4-dihydro product was isolated. With other dienes, among them butadiene, piperylene, and isoprene, addition of hydrogen occurred in all possible ways, and although there were several breaks in the curves, none of them corresponded to the half-hydrogenation point. When the hydrogenation of isoprene was stopped at the addition of one equivalent of hydrogen, the reaction mixture was found to contain 30 per cent of the saturated hydrocarbon and 30 per cent of unattacked isoprene, together with 12 to 15 per cent of each of the possible dihydro derivatives.<sup>3</sup> Muskat and Knapp (221) were able to isolate the 3,4-dihydro compound when phenylbutadiene was hydrogenated in the presence of platinum black, but Kuhn and Winterstein (177) could obtain no partially hydrogenated products from the  $\alpha,\omega$ -diphenylpolyenes with this catalyst.

Raney nickel gives more stepwise hydrogenation than does platinum black. Dupont and Pacquot (78) have shown by means of Raman spectra that the product isolated from the half-hydrogenation of isoprene over Raney nickel is an approximately equimolar mixture of the 1,4- and 3,4-dihydro compounds, 2-methyl-2-butene and 2-methyl-1-butene; no 1,2-dihydro compound, 2-methyl-3-butene, was obtained. The hydrogenation of  $\beta$ -myrcene is of considerable interest (see page 154). When it is hydrogenated over Raney nickel or palladium-charcoal, the main product is that formed by 1,4-addition of hydrogen to the conjugated system (I); some of the 1,2-dihydro compound is also obtained (II), but in neither case is any 3,4-dihydro compound formed, nor is the isolated double bond attacked. When the catalyst is platinum oxide-platinum black, the reaction does not stop with addition of 1 mole of hydrogen, and the first product isolated is the monoolefin (III), in which only the highly substituted double bond remains unattacked. Sodium in alcohol yields I, mainly (75, 76).

Alloëcimene, in which there are three double bonds in conjugation, gives no homogeneous product when the reaction is stopped at the addition of 1 mole of hydrogen, but with 2 moles the product is largely 3,7-dimethyl-3-octene (IV),

<sup>3</sup> These figures cannot be considered as accurate, for the method of analysis involved long contact (several months) with liquid sulfur dioxide, and some rearrangement probably occurred.

together with a little 3,7-dimethyl-2-octene (4); hence 1,4-addition of hydrogen must have occurred at some stage.

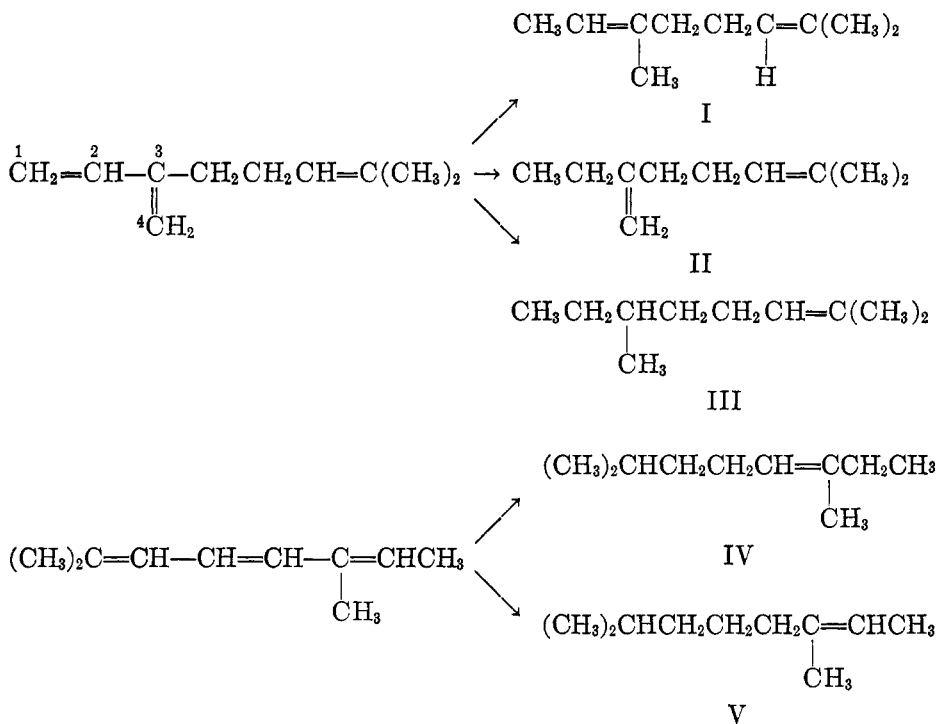

The hydrogenation of higher polyunsaturated acids, in which the carboxyl group is removed from the conjugation, has also been shown to go in a stepwise fashion, at least to some extent. Hydrogenation of 9,11-linoleic acid in the presence of reduced nickel yields some  $\Delta^{10}$ -elaidic acid, and some partial hydrogenation of eleostearic acid occurred in the presence of this catalyst also (40).

When two or more ethylenic groups are in extended conjugation with a carbonyl group, as in vinylacrylic acid, sorbic acid, etc., the results recorded are contradictory. Several workers (137, 231) have reported that the saturation of both double bonds in these compounds takes place simultaneously when platinum black is used, and that no dihydro products can be isolated. On the other hand, Farmer and his coworkers, who also used platinum black as catalyst, were able to isolate dihydro compounds from vinylacrylic acid (94), sorbic acid (94, 95, 97, 98, 99), and some of the methylsorbic acids (94), as well as muconic acid (97), although the bulk of the product in each case consisted of unreduced acid and the saturated derivative. Isaacs and Wilson (144, 145, 146) also obtained dihydro derivatives from sorbic acid, as did Muskat and Knapp (221) from vinylacrylic acid, and Lebedev and Yakubchik (191) from piperic acid with the Adams catalyst. It is difficult to account for these discrepancies when the same type

of catalyst was used by different workers. A part of the trouble may be found in the difficulties of analyzing the mixtures, and another source of error may be in the age of the catalyst, as Farmer and Galley (95) found that a sample of the Adams catalyst which had been used once or twice gave a larger proportion of stepwise hydrogenation than did a fresh sample.

As with the diene hydrocarbons, palladium and Raney nickel catalysts have more tendency than platinum to bring about a stepwise hydrogenation of diene acids. This is shown in table 21, taken from the work of Farmer and Hughes (98).

The addition of hydrogen in the presence of these catalysts to the system  $\overset{4}{\text{C}}=\overset{3}{\text{C}}-\overset{2}{\text{C}}=\overset{1}{\text{C}}-\text{COOH}$  tends to occur in the 3,4-positions, although some 1,4-addition is also obtained. This stands in contrast to the results of reduction by alkali amalgams, in which 1,2- and 1,4-additions of hydrogen occur, but no 3,4-addition.

When an acetylenic bond is in conjugation with an ethylenic bond, it is frequently possible to obtain selective hydrogenation of the former, with the forma-

TABLE 21  
*Effect of catalysts on the hydrogenation of sorbic acid (98)*

CATALYST	SORBIC ACID AT HALF-REDUCTION	SATURATED ACID AT HALF-REDUCTION	DIHYDRO COMPOUNDS
	<i>per cent</i>	<i>per cent</i>	<i>per cent</i>
Raney nickel.....	4	4	83
Platinum black.....	44	44	12
Palladium oxide.....			88
Palladium-barium sulfate.....			90

tion of the corresponding diene. Palladium catalysts seem to be especially effective for this, but nickel ones may sometimes be used (55). Vinylacetylene with palladium catalysts yields butadiene, together with some butene and polymers (133, 134), whereas the reaction is entirely unselective when platinum black is the catalyst (192), and nickel-alumina catalyzes the formation of the saturated compound directly (192).

Raney iron can be used to convert a substituted vinylacetylene to the butadiene derivative; Thompson and Wyatt (302) found that 2-methyl-1-buten-3-yne,  $\text{CH}_2=\text{C}(\text{CH}_3)\text{C}\equiv\text{CH}$ , was thereby reduced to isoprene, and the reaction stopped at this point.

Very little work has been reported on the partial hydrogenation of hydrocarbons with crossed conjugated systems. Dialkylfulvenes, which undergo 1,4-reduction by chemical methods, on catalytic hydrogenation over palladium or platinum show no sharp breaks in the hydrogenation curve, and yield no partially hydrogenated products (153).

In the hydrogenation of diphenylfulvene, addition of the first mole of hydrogen

is non-selective, to the ring, but when palladium is the catalyst, a tetrahydro compound can be isolated (158).

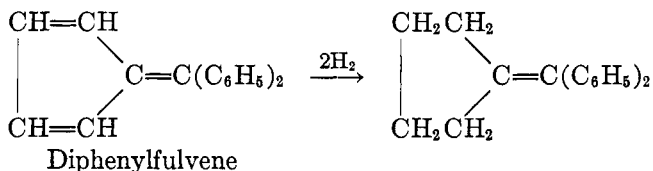

With divinylacetylenes, the triene stage cannot be isolated. When platinum catalysts are used, the reaction is entirely unselective, and continues to the saturated derivative; with palladium catalysts a monoolefin can sometimes be isolated (354, 355).

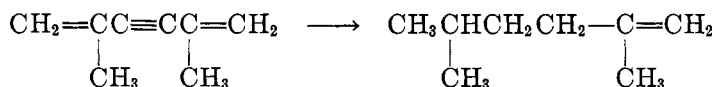

Blomquist and Marvel (37) were, however, unable to find any selective hydrogenation of 4,7-dipropyl-3,7-decadien-5-yne,  $\text{CH}_3\text{CH}_2\text{CH}=\text{C}(\text{C}_3\text{H}_7)\text{C}\equiv\text{CC}(\text{C}_3\text{H}_7)=\text{CHCH}_2\text{CH}_3$ .

Very little work has been reported on the course of the hydrogenation of conjugated diacetylenes. Grignard and Tcheoufaki (126) have found that both 1,4- and 1,2-addition of hydrogen occurs with diphenyldiacetylene in the presence of platinum black, for they isolated diphenylbutatriene, diphenylbutadiene, and diphenylacetylene.

The results on the partial hydrogenation of conjugated hydrocarbons and diene acids are compiled in table 22.

#### F. Hydrogenation of aromatic hydrocarbons

The catalytic addition of hydrogen to the double bonds of an aromatic ring is much more difficult than it is to open-chain unsaturated linkages, and therefore requires more strenuous conditions of temperature and pressure, or a longer reaction time. Nevertheless, there is a wide variety of catalysts which will bring about the hydrogenation of aromatic systems, and the reaction is one of considerable commercial importance. For a complete discussion of the subject, the reader is referred to the books of Ellis (84), Adkins (4), Ipatieff (139), Berkman, Morrell, and Egloff (34) and others.

##### 1. Hydrogenation of benzene and its derivatives

Benzene and its homologs can be reduced to the cyclohexane derivatives in the presence of platinum black catalysts, at pressures of 1 to 4 atm. and at or near room temperature; the reaction proceeds best in acetic acid solution (3, 327), or in the presence of a small amount of hydrogen halide acid (52), the acid seeming to exert a specific promoting effect. The hydrogenation is inhibited by sodium hydroxide (109). Willstätter and Waldschmidt-Leitz (331) have shown that the presence of oxygen in a platinum black catalyst is essential, but this is not true for colloidal platinum and palladium catalysts (284). Colloidal platinum



TABLE 22  
Partial hydrogenation of conjugated compounds

COMPOUND REDUCED	CATALYST	PRODUCTS OF PARTIAL HYDROGENATION	REFERENCES
Isoprene.....	Raney Ni	50% 1,4- and 50% 3,4-dihydro	(78)
$\begin{array}{cccc} 4 & 3 & 2 & 1 \\ \text{CH}_2 & =\text{CH} & \text{C} & =\text{CH}_2 \\ & &   & \\ & & \text{CH}_3 & \end{array}$	Pt oxide	30% saturated; 12-15% of each possible dihydro compound	(189, 190)
Dimethylbutadiene.....	Raney Ni	63% 1,2-dihydro; 37% 1,4-dihydro	(78)
$\begin{array}{cccc} 1 & 2 & 3 & 4 \\ \text{CH}_2 & =\text{C} & -\text{C} & =\text{CH}_2 \\ &   &   & \\ & \text{H}_3\text{C} & \text{CH}_3 & \end{array}$	Raney Ni	63% 1,4-dihydro; 37% 1,2-dihydro	(76)
$\beta$ -Myrcene.....	Pt oxide	No dihydro; 3,7-dimethyl-6-octene	(76)
$\begin{array}{ccc} 1 & 2 & 3 \\ \text{CH}_2 & =\text{CH} & \text{C} \\ & &    \\ & & \text{CH}_2 \end{array} \text{CH}_2\text{CH}_2\text{C}=\text{C}(\text{CH}_3)_2$	Palladium	75% 1,4-dihydro; 25% 1,2-dihydro	(76)
Alloöcimene.....	Raney Ni	1,2,3,6-Tetrahydro; some 1,2,3,4-tetrahydro	(77)
$\begin{array}{cccccc} 1 & 2 & 3 & 4 & 5 & 6 \\ (\text{CH}_3)_2\text{C} & =\text{CH} & \text{CH} & =\text{CH} & \text{C} & =\text{CH} & \text{CH}_3 \\ & & & &   & \\ & & & & \text{CH}_3 & \end{array}$	Pt oxide	Same as given by Raney nickel	(77)
1-Phenylbutadiene.....	Pt oxide	3,4-Dihydro	(221)
$\begin{array}{cccc} 1 & 2 & 3 & 4 \\ \text{C}_6\text{H}_5\text{CH} & =\text{CH} & \text{CH} & =\text{CH}_2 \end{array}$	Pt oxide	Non-selective	(12)
2,3-Diphenylbutadiene.....	Pt oxide	Not reduced	(43)
$\begin{array}{cccc} 1 & 2 & 3 & 4 \\ \text{CH}_2 & =\text{C} & -\text{C} & =\text{CH}_2 \\ &   &   & \\ & \text{C}_6\text{H}_5 & \text{C}_6\text{H}_5 & \end{array}$	Pt oxide	Non-selective	(177)
1,2,3,4-Tetraphenylbutadiene.....	Pt oxide	Non-selective	(334)
$\alpha,\omega$ -Diphenylpolyenes.....	Ni, 180°C.	$\Delta^{10}$ - <i>cis</i> -Elaidic acid	(40)
$\text{C}_6\text{H}_5(\text{CH}=\text{CH})_n\text{C}_6\text{H}_5$	Pt oxide	Non-selective	(137)
1,1,6,6-Tetraphenyl-1,3,5-hexatriene	Pt oxide	3,4-Dihydro	(221)
9,11-Linoleic acid.....	Pt oxide	28% 3,4-dihydro; 8% 1,2-dihydro; 32% saturated compound	(94)
Vinylacrylic acid.....	Pt oxide	7% 3,4-dihydro; 44% of saturated compound	(94, 97)
$\begin{array}{cccc} 4 & 3 & 2 & 1 \\ \text{CH}_2 & =\text{CH} & \text{CH} & =\text{CHCOOH} \end{array}$	Pt oxide	Non-selective	(137)
Sorbic acid	Pt oxide	31% 3,4-dihydro; 63% saturated	(144, 332)
$\begin{array}{cccc} 4 & 3 & 2 & 1 \\ \text{CH}_3\text{CH} & =\text{CH} & \text{CH} & =\text{CHCOOH} \end{array}$	Pd-BaSO <sub>4</sub>	90% 3,4-dihydro	(98)
	Raney Ni	83-86% 3,4-dihydro	(98, 332)

TABLE 22—Continued

COMPOUND REDUCED	CATALYST	PRODUCTS OF PARTIAL HYDROGENATION	REFERENCES
$\alpha$ -Methylsorbic acid..... $\begin{array}{cccc} 4 & 3 & 2 & 1 \\ \text{CH}_3\text{CH}=\text{CHCH}=\text{CCOOH} \\   \\ \text{CH}_3 \end{array}$	Pt oxide	21% 3,4-dihydro; 26% 1,4-dihydro	(94)
$\beta$ -Methylsorbic acid..... $\begin{array}{cccc} 4 & 3 & 2 & 1 \\ \text{CH}_3\text{CH}=\text{CHC}=\text{CHCOOH} \\   \\ \text{CH}_3 \end{array}$	Pt oxide	34% 3,4-dihydro; 14% 1,4-dihydro	(94)
Muconic acid..... $\begin{array}{cccc} 1 & 2 & 3 & 4 \\ \text{HOOCCH}=\text{CHCH}=\text{CHCOOH} \end{array}$	Pt oxide	Non-selective	(137)
Piperic acid..... $\text{CH}_2\text{O}_2\text{C}_6\text{H}_4\text{CH}=\text{CHCH}=\text{CHCOOH}$	Pt oxide	11% 3,4- and 7% 1,4-dihydro; 40% saturated	(97)
Methysticin..... $\begin{array}{cccc} 4 & 3 & 2 & 1 \\ \text{ArCH}=\text{CHCH}=\text{CHCOCH}_2\text{COOH} \end{array}$	Pt oxide	33% dihydro	(191)
	Colloidal Pd	Non-selective	(231)
	Colloidal Pd	50% dihydro	(191)
	Pd (on sodium salt)	1,2-Dihydro	(115)
	Pd (on methyl ester)	3,4-Dihydro	(115)
Vinylacetylene..... $\text{CH}_2=\text{CHC}\equiv\text{CH}$	Palladium	1,3-Butadiene in good yields (60-80%)	(133, 134, 192)
Methylvinylacetylene..... $\begin{array}{cccc} 1 & 2 & 3 & 4 \\ \text{HC}\equiv\text{C}-\text{C}=\text{CH}_2 \\   \\ \text{CH}_3 \end{array}$	Platinum Raney Fe	Non-selective 1,2-Dihydro (isoprene)	(192) (302)
$\text{CH}_3\text{CHC}\equiv\text{CCH}=\text{CH}_2$ ..... $\begin{array}{cccc} 1 & 2 & 3 & 4 \\ \text{CH}_3 \\   \\ \text{CH}_3\text{CHC}\equiv\text{CCH}=\text{CH}_2 \end{array}$	Platinum	Non-selective	(355)
$\text{C}_2\text{H}_7\text{CC}\equiv\text{CCH}=\text{CH}_2$ ..... $\begin{array}{cccc} 1 & 2 & 3 & 4 \\ \text{OH} \\   \\ \text{C}_2\text{H}_7\text{CC}\equiv\text{CCH}=\text{CH}_2 \end{array}$	Palladium	1,2-Dihydro	(366)
$\text{C}_2\text{H}_5\text{CC}\equiv\text{CCH}=\text{CH}_2$ ..... $\begin{array}{cccc} 1 & 2 & 3 & 4 \\ \text{OH} \\   \\ \text{CH}_3 \\   \\ \text{C}_2\text{H}_5\text{CC}\equiv\text{CCH}=\text{CH}_2 \end{array}$	Palladium	1,2-Dihydro	(366)
$\text{C}_2\text{H}_5\text{CC}\equiv\text{CCH}=\text{CH}_2$ ..... $\begin{array}{cccc} 1 & 2 & 3 & 4 \\ \text{OH} \\   \\ \text{OH} \\   \\ \text{C}_2\text{H}_5\text{CC}\equiv\text{CCH}=\text{CH}_2 \end{array}$	Palladium	1,2-Dihydro	(349)
Diphenyldiacetylene..... $\begin{array}{cccc} 1 & 2 & 3 & 4 \\ \text{C}_6\text{H}_5\text{C}\equiv\text{CC}=\text{C}(\text{COOH})_2 \end{array}$	Pd, pyridine	1,2-Dihydro ( <i>cis-cis</i> )	(198)
	Colloidal Pd	1,2,3,4-Tetrahydro: 25% <i>cis-cis</i> , 75% <i>cis-trans</i>	(161)
	Pd-charcoal	90% <i>cis-trans</i> -1,2,3,4-tetrahydro	(228)
	Ni-charcoal	33% <i>cis-cis</i> tetrahydro	(228)

TABLE 22—Concluded

COMPOUND REDUCED	CATALYST	PRODUCTS OF PARTIAL HYDROGENATION	REFER-ENCES
Divinylacetylene..... $\text{CH}_2=\text{CHC}\equiv\text{CCH}=\text{CH}_2$	Ni, 35°C.	3-Hexene	(55)
$\text{CH}_2=\text{CC}\equiv\text{CC}=\text{CH}_2$ ..... $\begin{array}{c} \text{CH}_3 \quad \text{CH}_3 \\   \quad   \\ \text{C}_2\text{H}_5\text{CH}=\text{CC}=\text{C}-\text{C}=\text{CHC}_2\text{H}_5 \end{array}$	Colloidal Pd	Mainly 2,5-dimethyl-1-hexene	(355)
$\text{C}_2\text{H}_5\text{CH}=\text{CC}=\text{C}-\text{C}=\text{CHC}_2\text{H}_5$ ..... $\begin{array}{c} \text{C}_2\text{H}_7 \quad \text{C}_3\text{H}_7 \\   \quad   \\ \text{RC}=\text{CC}\equiv\text{CC}=\text{CR} \end{array}$	Pt oxide	Non-selective	(37)
$\text{RC}=\text{CC}\equiv\text{CC}=\text{CR}$ ..... $\begin{array}{c} \text{R} \quad \text{R} \\   \quad   \\ \text{RCH}_2\text{CHCH}=\text{CHCHCH}_2\text{R} \end{array}$	Ni	$\text{RCH}_2\text{CHCH}=\text{CHCHCH}_2\text{R}$	(127)

(224) and palladium catalysts (286), nickel black (304), and osmium-asbestos (359) will also bring about the hydrogenation of benzene under mild conditions.

Reduced nickel is an effective catalyst, either for use with the Sabatier-Senderens technique at 180°C. (261), or for liquid-phase hydrogenation at higher temperatures and pressures of about 80 atm. (225); Raney nickel (4, 6), nickel-kieselguhr (5), and nickel-alumina catalysts (83) may also be used at temperatures varying from 100° to 175°C. and pressures of 30 to 170 atm. Nickel oxide catalysts can be used at higher temperatures and pressures (139). Reduced copper is not an efficient catalyst for the hydrogenation of benzene unless it contains traces of nickel (141), and copper chromite, except in a few rare cases, is not a satisfactory catalyst for the hydrogenation of aromatic nuclei (357). With practically all of these catalysts the presence of small amounts of impurities in the compound being hydrogenated—especially sulfur-containing impurities—inhibits the reaction; recently sulfur-containing catalysts, such as the molybdenum sulfides, have been developed which are much less sensitive to poisoning, but these catalysts require very high temperatures (in the neighborhood of 400°C.) to be effective.

The hydrogenation of benzene and of its alkyl derivatives cannot be stopped at any intermediate stage, but proceeds directly to the cyclohexane, which may or may not undergo secondary reactions, depending on the conditions. This does not prove, however, that the hydrogenation is not a stepwise one, for it is possible that the intermediate compounds, being cyclic dienes or olefins, are hydrogenated more readily than the original aromatic compound, and are formed, but are immediately hydrogenated. Some evidence for a stepwise course has been presented by Truffault (305), who found that when benzene is hydrogenated over nickel in the presence of phosphorus pentoxide as inhibitor, cyclohexylbenzene is obtained; he considered that a condensation occurred between benzene and a partially hydrogenated product to form this substance.

The hydrogenation of phenols has definitely been shown to take a stepwise course; Vavon and his students (311, 312) found that cyclohexanone is an intermediate in the hydrogenation of phenol to cyclohexanol, and Grignard was

able, by working at pressures of 18 to 22 mm., to isolate the enol of cyclohexanone and to establish the course of the reaction as follows:

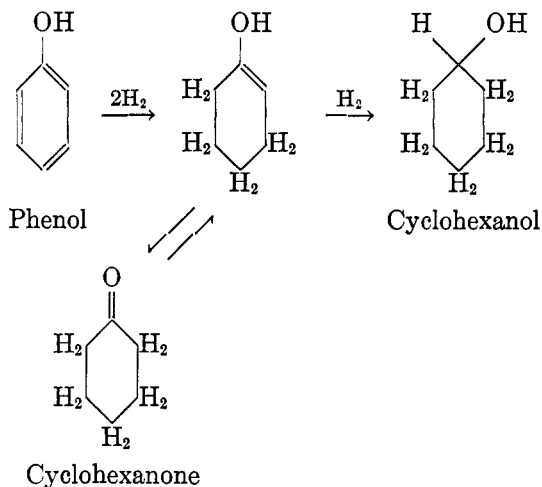

The effect of substituents in the benzene ring on the ease of hydrogenation of the nucleus is by no means clear-cut, and contradictory results have been reported. Phenols seem to undergo hydrogenation more easily than do the hydrocarbons over nickel and platinum (4, 50, 71, 200a, 314); etherification of the hydroxyl group removes this effect. Amine groups retard the hydrogenation (71, 200a), as do carbethoxy groups (4); Willstätter and Hatt (327), however, found that benzoic acid was hydrogenated more easily than benzene in the presence of platinum black. Considerable confusion exists as to the effect of alkyl groups. Willstätter and Hatt (327), using platinum black, found that toluene and durene were hydrogenated more easily than benzene; Altman (13) has obtained similar results for a molybdenum sulfide catalyst. On the other hand, several workers have reported that alkyl groups decrease the ease of hydrogenation of the benzene ring in the presence of nickel-alumina (82), nickel black (305), palladium (8), and platinum catalysts (224). Lozovoi and Dyakova (199), using nickel on alumina, found that the size of the side chain, in varying from  $C_1$  to  $C_8$ , had little effect on the ease of hydrogenation, but that the number of side chains had a marked effect (200). They obtained the relative reactivities recorded in table 23.

Some work has been done on the stereochemical configuration of the products obtained from the hydrogenation of disubstituted benzenes, but the results are somewhat confusing. The hydrogenation of the xylenes in the presence of colloidal platinum in acetic acid solution, according to Skita (285), yields a mixture of the *cis*- and *trans*-dimethylcyclohexanes, whereas cymene gives the *cis* saturated compound. Adams and Marshall (3), on the other hand, using the Adams catalyst and acetic acid as solvent, obtained only the *trans*-dimethyl-

cyclohexane from *m*-xylene. Zelinsky and Margolis (360) and Margolis (206) have found that *o*- and *p*-xylenes on treatment with hydrogen at 50–70°C. in the presence of osmium-asbestos are converted to the *cis*-dimethylcyclohexanes; if the Sabatier-Senderens procedure is used, with reduced nickel, at 170–180°C., the *trans* isomers are obtained. Since the *cis* compound is converted to the *trans* by passage over nickel at 170°C., but the *trans* is not changed to the *cis* in the presence of osmium at 70°C., it is probable that the primary product in both cases is the *cis* form, and that this may or may not rearrange to the *trans*, depending on the conditions.

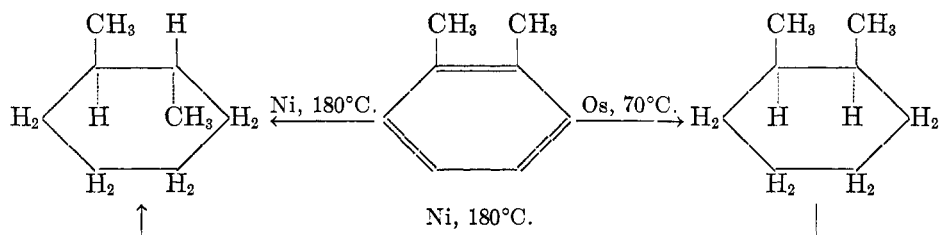

Hydrogenation of alkylphenols over platinum catalysts, in acetic acid solution, yields either the *cis*-alkylcyclohexanol, or a mixture of the *cis* and *trans* forms,

TABLE 23

*Relative reactivities in hydrogenations over nickel-alumina (200)*

COMPOUND	RELATIVE REACTIVITY	COMPOUND	RELATIVE REACTIVITY
Styrene.....	900	Benzene.....	1
1-Hexene.....	306	Toluene.....	0.4
Cyclopentene.....	294	Xylene.....	0.22
Cyclohexene.....	150	Trimethylbenzene.....	0.1
1-Methyl-3-cyclohexene.....	134	Tetramethylbenzene.....	0.04
1-Methyl-1-cyclohexene.....	5	Pentamethylbenzene.....	0.005
Naphthalene.....	3.3	Hexamethylbenzene.....	0.001

with the former predominating (283, 311, 313). At higher temperatures, over a nickel catalyst, the *trans* form may be obtained (20).

In the hydrogenation of benzene derivatives, the cyclohexane is usually formed in good yield, and without large amounts of side reactions. In some cases, however, hydrogenolysis may occur, or the reaction product may undergo secondary reactions. Adkins (4, 357) observed that phenol ethers, benzyl alcohol, and pentaphenylethane undergo some hydrogenolysis, with the formation of cyclohexane, toluene, and tri- and di-cyclohexylmethanes, respectively. When benzene is hydrogenated at high temperatures, the cyclohexane formed is partially changed to methylcyclopentane, and other deep-seated changes may occur. Thus, using nickel oxide at 460°C. (272), or molybdenum sulfide at 430°C.

(14, 249, 250), methyl cyclopentane is obtained, and in some cases hexane, methane, toluene, and cyclopentane have been isolated (225). Alkylbenzenes may undergo migration or cleavage of the alkyl groups; toluene at 400°C. over molybdenum sulfide yields methylcyclohexane, dimethylcyclopentane, cyclopentane, etc.

In contrast to the simple benzene derivatives, the polynuclear hydrocarbons are hydrogenated stepwise, and the intermediate steps can frequently be isolated. Hydrogenation of many of these hydrocarbons is easier than that of benzene, owing to the more aliphatic nature of some of the double bonds.

## 2. Hydrogenation of naphthalene

Naphthalene can be hydrogenated to tetralin or decalin, depending on the conditions. In contrast to reduction by chemical methods, no dihydronaphthalene can be isolated from the catalytic hydrogenation (255). In some cases tetralin is definitely an intermediate in the formation of decalin; in others the decalin appears to be formed directly. Willstätter and Seitz (329) have found that a platinum catalyst rich in oxygen causes the formation of tetralin at room temperature; if the catalyst is poor in oxygen, decalin is formed directly, and no tetralin can be detected. The decalin so obtained has been shown to be the *cis* form (330). Maillard (204) has shown that hydrogenation of naphthalene at 20°C. with active nickel also leads to the direct formation of decalin; above 60°C., however, the reaction is stepwise, and tetralin can be isolated.

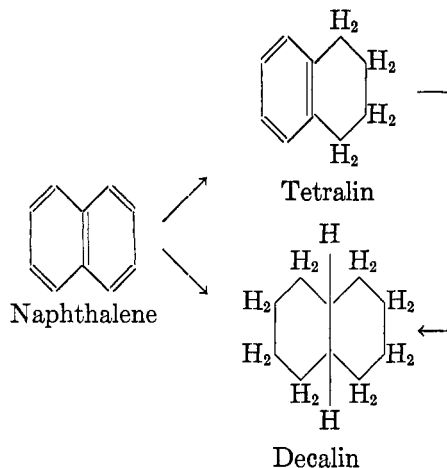

In many cases, both tetralin and decalin are formed; in others, either compound can be obtained by changing the temperature and pressure. Table 24 contains a summary of some of the work in this field.

If the temperature is too high, the tetralin and decalin formed may undergo decomposition to yield benzene derivatives. Reduced nickel at 460–500°C. causes the formation of some of these (225), as do nickel and iron oxide catalysts

above 450°C. (140), molybdenum sulfide above 360°C. (245), and molybdenum oxide at 435°C. (81).

Sodium and sodium hydride, which do not catalyze the addition of hydrogen to benzene, are effective catalysts for the hydrogenation of naphthalene (33a, 128, 131, 132), and for other compounds which are capable of adding sodium, such as styrene. These catalysts are most effective at temperatures of about

TABLE 24  
*Catalytic hydrogenation of naphthalene*

CATALYST	TEMPERATURE	PRESSURE	MAIN PRODUCT	REFERENCES
	°C.			
Reduced Cu.....	200	80 atm.	Tetralin	(171)
Reduced Cu.....	260	80 atm.	Decalin	(171)
Pt black.....	Room	Atmospheric	Decalin	(329)
Osmium-asbestos.....	90-160	Atmospheric	Decalin	(359)
NiO, CuO, Fe <sub>2</sub> O <sub>3</sub> .....	450		Tetralin	(140)
Ni-Al.....	200	100 atm.	Tetralin	(252)
Ni-kieselguhr.....	200	100 kg.	Tetralin	(319)
Raney Ni.....	150	150 kg.	Tetralin	(237)
Raney Ni.....	170-200	150 kg.	Decalin	(237)
Raney Ni.....	100		Tetralin and decalin	(223)
Ni.....	180	Atmospheric	Tetralin	(255)
Ni.....	200	Atmospheric	Decalin	(255)
Cu-Cr.....	200		Tetralin	(223)
MoS <sub>3</sub> .....	380	100 atm.	Tetralin	(246)
MoS <sub>3</sub> .....	400	200 atm.	Tetralin and decalin	(245)
Na, NaH.....	270	120 kg.	Tetralin	(131, 33a)
Ca.....	270	2000 lb.	Tetralin	(33a)

270-300°C., at cold hydrogen pressures of about 120 kg. per square centimeter, and in the case of naphthalene catalyze the formation of tetralin.

The naphthols are more easily hydrogenated than naphthalene; with  $\alpha$ -naphthol either ring may be hydrogenated preferentially, as Raney nickel at 150°C. causes hydrogenation to occur chiefly in the unsubstituted ring, and with copper chromite it is the substituted ring that is attacked (4). With  $\beta$ -naphthol,

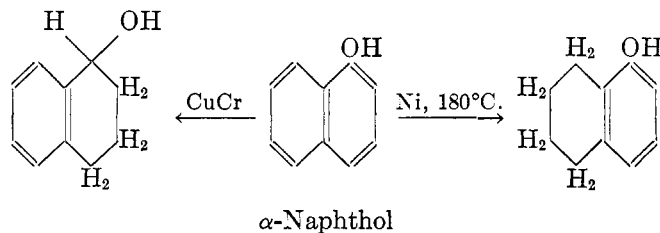

however, both catalysts cause hydrogenation to occur chiefly in the substituted ring (4, 50).

The hydrogenation of alkyl derivatives of naphthalene has not received much attention. Acenaphthene, like naphthalene, is hydrogenated to the tetrahydro stage in the presence of nickel at 210°C. and moderate pressures (47, 121); if the Sabatier-Senderens technique is used, at 150°C. a mixture of tetrahydro- and decahydro-acenaphthenes is obtained (121).  $\alpha$ -Ethylnaphthalene can also be hydrogenated to the tetrahydro or decahydro stage over nickel (193).

### 3. Hydrogenation of anthracene

Anthracene can be hydrogenated in stages, the reaction usually proceeding to the octahydro stage, but the exact course of the hydrogenation is not clear. Schroeter (273) considered that the dihydro compound is an intermediate when nickel is used as a catalyst at 150–180°C. and 20 atm., and that this, in the presence of the catalyst, rearranges and is then hydrogenated further:

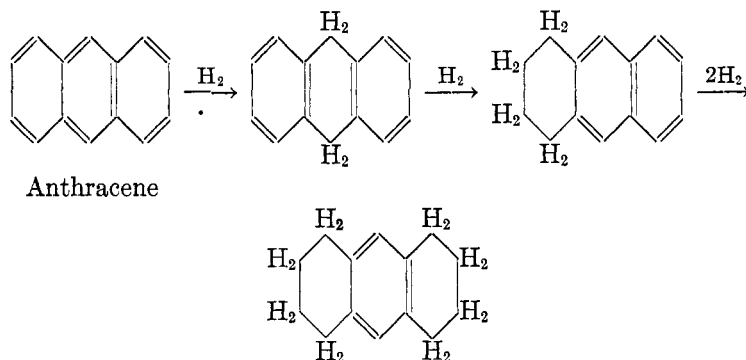

This mechanism is supported by the fact that the 9,10-tetraalkyldihydroanthracenes (I), in which a rearrangement such as that postulated above is not possible, are not hydrogenated in the presence of platinum black or Raney nickel at 200°C. and a pressure of 100 kg. per square centimeter, whereas the 9,10-dialkyldihydroanthracenes (II), which could rearrange, are hydrogenated under these conditions (208).

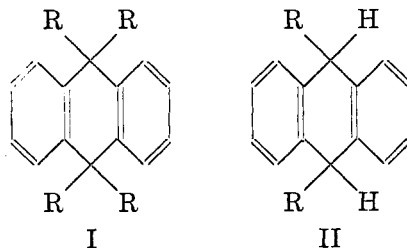

Fries, Schilling, and Littmann (110), on the other hand, do not consider that the 9,10-dihydro compound is necessarily an intermediate when platinum or nickel is the catalyst, for when 1 mole of hydrogen is added to 1 mole of



anthracene, only one-half of the theoretical amount of dihydro derivative is formed. They suggested that two simultaneous processes occur, as follows:

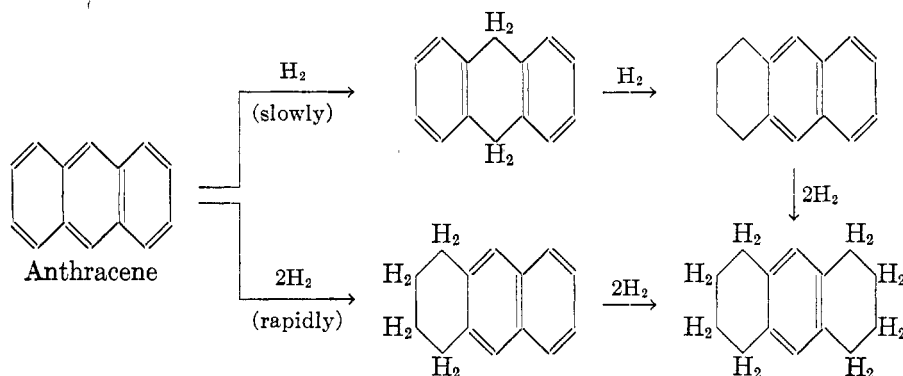

Fieser and Hershberg (103) have found evidence for the direct formation of the tetrahydro compound, not involving a meso dihydro as intermediate, from a study of the hydrogenation of benzanthracene and methylbenzanthracene. When either of these compounds (III) is hydrogenated in the presence of platinum black, it forms a tetrahydro derivative (IV). Treatment of the original compound (III) with sodium, followed by hydrolysis, yields the meso dihydrobenzanthracene (V), and this on catalytic hydrogenation does *not* give the tetrahydro compound (IV), but rather a hexahydro derivative (VI), in which hydrogenation has occurred in another part of the ring system.

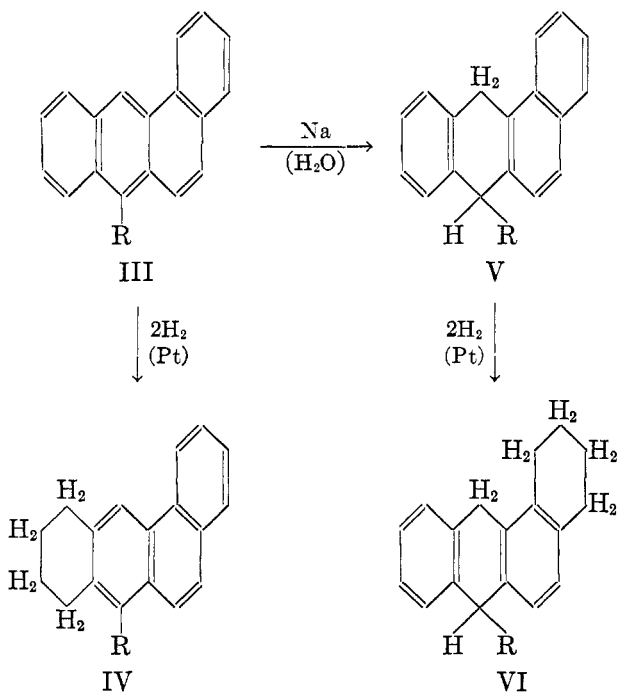

Anthracene can be converted to tetrahydroanthracene and a mixture of the octahydro compounds, in which the symmetrical form predominates, with a wide variety of catalysts, such as nickel-pumice at 160°C. (205), nickel-kieselguhr at 180–280°C. (320), and molybdenum sulfide at 350°C. (247, 248). Both symmetrical and unsymmetrical octahydroanthracenes can be obtained; these have been shown to rearrange into each other under the conditions used. Long-continued hydrogenation of anthracene or of the octahydroanthracenes yields the perhydro derivative; this exists in at least two forms (110, 247, 248, 320).

#### 4. Hydrogenation of phenanthrene

Like anthracene, phenanthrene can be hydrogenated stepwise, the first attack being at the 9,10-positions. The aliphatic nature of this double bond is demonstrated by the fact that it can be hydrogenated using copper chromite as catalyst, although this catalyst is generally inert for the hydrogenation of aromatic nuclei (79, 80).

Schröeter (274) has shown that the hydrogenation of phenanthrene occurs as indicated below, the steps being established by synthesis of the intermediates:

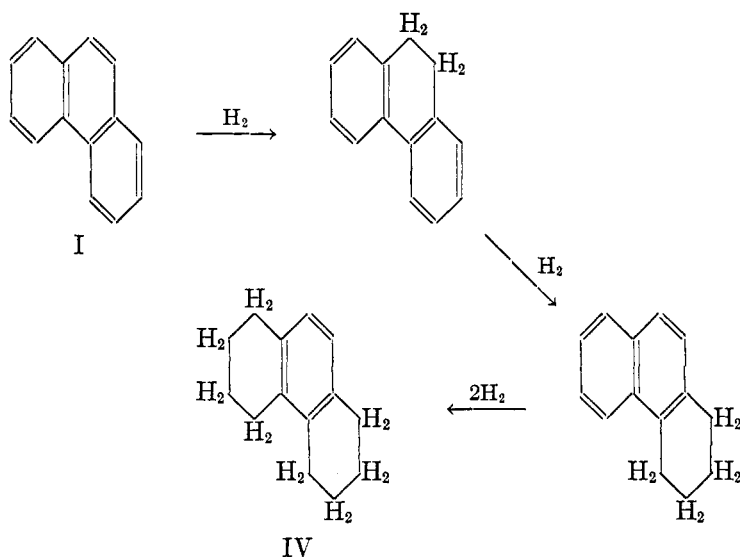

The reaction tends to stop at the octahydro stage; usually the symmetrical octahydro compound (IV) is obtained, but some of the unsymmetrical derivative (V) can be isolated when Raney nickel is used at 130°C. (80). The dodecahydrophenanthrene (VI) can be obtained if Raney nickel is used at 200°C. (80).

By a suitable choice of catalyst and conditions the lower hydrogenation products can be made to predominate; thus with a copper chromite catalyst at 150°C. the 9,10-dihydro compound is obtained (53); when Raney nickel is used at 110°C. (80), palladium black at room temperature (49), spongy palladium at

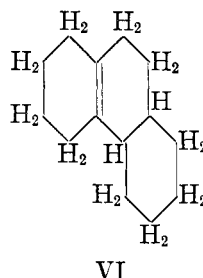
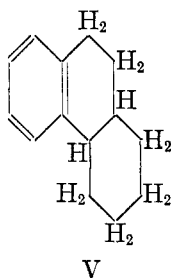

160°C. (49), or nickel at 150°C. (274), tetrahydrophenanthrene is formed. Strenuous hydrogenation causes the formation of a perhydro compound (4, 139, 247).

### 5. Hydrogenation of fluorene and indene

As would be expected, the isolated double bond of indene is readily hydrogenated (47, 220). Fluorene, on the other hand, is hard to hydrogenate, and with nickel oxide requires a long reaction time at 300°C. to form decahydrofluorene (262). With an osmium catalyst at 300°C. the main product is likewise the decahydro compound, but if a small amount of cerium oxide is present, the perhydrogenated product is formed almost entirely (262).

### REFERENCES

- (1) ACKERMANN, P.: *Brennstoff Chem.* **18**, 357 (1937); *Chem. Abstracts* **31**, 8501.
- (2) ADAMS, R., AND GARVEY, B. S.: *J. Am. Chem. Soc.* **48**, 477-82 (1926).
- (3) ADAMS, R., AND MARSHALL, J. R.: *J. Am. Chem. Soc.* **50**, 1970 (1928).
- (4) ADKINS, H.: *Reactions of Hydrogen with Organic Compounds over Chromium Oxide and Nickel Catalysts*. University of Wisconsin Press, Madison, Wisconsin (1937).
- (5) ADKINS, H., CRAMER, H. I., AND CONNOR, R.: *J. Am. Chem. Soc.* **53**, 1402 (1931).
- (6) ADKINS, H., CRAMER, H. I., AND ZARTMAN, W. H.: *J. Am. Chem. Soc.* **53**, 1425 (1931).
- (7) ADKINS, H., DIWOKY, F. F., AND BRODERICK, A. E.: *J. Am. Chem. Soc.* **51**, 3418 (1929).
- (8) ALCHUDZHAN, A. A., WEDENSKII, A. A., ZHARKOVA, V. R., AND FROST, A. V.: *J. Gen. Chem. (U. S. S. R.)* **4**, 1168 (1934); *Chem. Abstracts* **29**, 3220.
- (9) ALDER, K., AND BACKENDORF, K. H.: *Ann.* **535**, 113 (1938).
- (10) ALEXANDER, L. L., AND FUSON, R. C.: *J. Am. Chem. Soc.* **58**, 1745 (1936).
- (11) ALEXANDER, L. L., JACOBY, A. L., AND FUSON, R. C.: *J. Am. Chem. Soc.* **57**, 2208 (1935).
- (12) ALLEN, C. F. H., ELIOT, C. G., AND BELL, A.: *Can. J. Research* **17**, 75 (1939).
- (13) ALTMAN, L., AND NEMTZOV, M.: *Acta Physicochim. U. R. S. S.* **1**, 429 (1934); *Chem. Abstracts* **29**, 7767.
- (14) ANDO, S.: *J. Soc. Chem. Ind. Japan* **42**, Suppl. binding 391 (1939); *Chem. Abstracts* **34**, 2339.
- (15) ARMSTRONG, E. F., AND HILDITCH, T. P.: *Proc. Roy. Soc. (London)* **A108**, 121 (1925).
- (16) ARONSTEIN, L., AND HOLLEMANN, A. F.: *Ber.* **22**, 1181 (1889).
- (17) ARONSTEIN, L., AND VAN NIEROP, A. S.: *Rec. trav. chim.* **21**, 452 (1902).
- (18) AUWERS, K. v., AND HEYNA, J.: *Ann.* **434**, 140 (1923).
- (19) AUWERS, K. v.: *Ann.* **434**, 166 (1923).
- (20) AUWERS, K. v., AND DERSCH, F.: *J. prakt. Chem.* **124**, 209 (1930).
- (21) AUWERS, K. v., AND PETERS, G.: *Ber.* **43**, 3111 (1910).

- (22) BACHMANN, W. E.: *J. Org. Chem.* **1**, 347 (1936).
- (23) BAEYER, A.: *Ann.* **269**, 145 (1892).
- (24) BAEYER, A.: *Ann.* **155**, 267 (1870).
- (25) BAMBERGER, E., AND LODTER, W.: *Ann.* **288**, 75 (1895).
- (26) BAMBERGER, E., AND LODTER, W.: *Ber.* **20**, 3073 (1887).
- (27) BAYER Co.: German patent 306,724; *Frld.* **13**, 313.
- (28) BAYER Co.: German patent 288,271 (1913); *Frld.* **12**, 58.
- (29) BERGMANN, E.: *Ber.* **63**, 2593 (1930).
- (30) BERGMANN, E., AND BOGRACHOV, E.: *J. Am. Chem. Soc.* **62**, 3016 (1940).
- (31) BERGMANN, E., AND SCHREIBER, W.: *Ann.* **500**, 118 (1933).
- (32) BERGMANN, E., WINTER, D., AND SCHREIBER, W.: *Ann.* **500**, 122 (1933).
- (33) BERGMANN, E., AND ZWECKER, O.: *Ann.* **487**, 155 (1931).
- (33a) BERGSTROM, F. W., AND CARSON, J. F.: *J. Am. Chem. Soc.* **63**, 2934 (1941).
- (34) BERKMAN, S., MORRELL, J. C., AND EGLOFF, G.: *Catalysis*. Reinhold Publishing Corporation, New York (1940).
- (35) BERNTHSEN, W.: *Ann.* **415**, 274 (1918).
- (36) BILLITZER, J.: *Monatsh.* **23**, 199 (1902).
- (37) BLOMQUIST, A. T., AND MARVEL, C. S.: *J. Am. Chem. Soc.* **55**, 1655 (1933).
- (38) BLUM, O.: *Ber.* **62**, 881 (1929).
- (39) BLUM-BERGMANN, O.: *Ann.* **484**, 26 (1930).
- (40) BOESEKEN, J., AND HOEVERS, R.: *Rec. trav. chim.* **49**, 1161 (1930).
- (41) BOURGUEL, M.: *Bull. soc. chim.* [4] **41**, 1443, 1475 (1927).
- (42) BOURGUEL, M.: *Bull. soc. chim.* [4] **45**, 1067 (1929).
- (43) BOURGUEL, M.: *Bull. soc. chim.* [4] **47**, 173 (1930).
- (44) BOURGUEL, M.: *Bull. soc. chim.* [4] **51**, 253 (1932).
- (45) BOURGUEL, M., AND GREDY, V.: *Compt. rend.* **189**, 757 (1929).
- (46) BRAND, K.: *Ber.* **46**, 2935, 2942 (1913).
- (46a) BRAND, K.: *Ber.* **54**, 1987 (1921).
- (47) VON BRAUN, J., AND KIRSCHBAUM, G.: *Ber.* **55**, 1680 (1922).
- (48) BRAY, R. H., AND ADAMS, R.: *J. Am. Chem. Soc.* **49**, 2101 (1927).
- (49) BRETEAU, P.: *Bull. soc. chim.* [4] **9**, 729 (1911).
- (50) BROCHET, A.: *Bull. soc. chim.* [4] **31**, 1270 (1922).
- (51) BROCKMAN, C. J.: *Electro-organic Chemistry*. John Wiley and Sons, Inc., New York (1926).
- (52) BROWN, J. H., DURAND, H. W., AND MARVEL, C. S.: *J. Am. Chem. Soc.* **58**, 1594 (1936).
- (53) BURGER, A., AND MOESETTIG, E.: *J. Am. Chem. Soc.* **57**, 2731 (1935).
- (54) BURTON, H., AND INGOLD, C. K.: *J. Chem. Soc.* **1929**, 2022.
- (55) CALCOTT, W. S., CARTER, A. S., AND DOWNING, F. B.: U. S. patent 2,156,936 (1939); *Chem. Abstracts* **33**, 6349.
- (56) CAMPBELL, K. N., AND EBY, L. T.: *J. Am. Chem. Soc.* **63**, 216 (1941).
- (57) CAMPBELL, K. N., AND EBY, L. T.: *J. Am. Chem. Soc.* **63**, 2683 (1941).
- (58) CAMPBELL, K. N., AND KERWIN, J. F.: Unpublished work.
- (59) CAMPBELL, K. N., AND O'CONNOR, M. J.: *J. Am. Chem. Soc.* **61**, 2897 (1939).
- (60) CAMPBELL, K. N., AND TOWNE, R. S.: Unpublished work.
- (61) CAMPBELL, K. N., AND YOUNG, E. E.: Unpublished work.
- (62) CAWLEY, C. M., EVANS, J. T., AND FARMER, E. H.: *J. Chem. Soc.* **1930**, 522.
- (63) CONANT, J. B.: *Chem. Rev.* **3**, 1 (1926-27).
- (64) CONANT, J. B., AND BLATT, A. H.: *J. Am. Chem. Soc.* **50**, 554 (1928).
- (65) CONANT, J. B., AND CUTTER, H. B.: *J. Am. Chem. Soc.* **48**, 1016 (1926).
- (65a) CONANT, J. B., AND CUTTER, H. B.: *J. Phys. Chem.* **28**, 1096 (1924).
- (66) COOK, J. W., AND HEWETT, C. L.: *J. Chem. Soc.* **1933**, 404.
- (67) COVERT, L. W., AND ADKINS, H.: *J. Am. Chem. Soc.* **54**, 4116 (1932).
- (68) DAVIS, H. S., THOMPSON, G., AND CRANDALL, G. S.: *J. Am. Chem. Soc.* **54**, 2340 (1932).
- (69) DECANS, V., AND DUFOUR, J.: *Bull. soc. chim.* [4] **37**, 1167 (1925).

- (70) DELÉPINE, M., AND HANEGRAAF, C.: Compt. rend. **205**, 185 (1937).  
(71) DWOKY, F. F., AND ADKINS, H.: J. Am. Chem. Soc. **53**, 1868 (1931).  
(72) DUPONT, G.: Compt. rend. **156**, 1623 (1913).  
(73) DUPONT, G.: Bull. soc. chim. [5] **3**, 1021 (1936).  
(74) DUPONT, G.: Bull. soc. chim. [5] **3**, 1030 (1936).  
(75) DUPONT, G., AND DESREUX, V.: Compt. rend. **203**, 623 (1936).  
(76) DUPONT, G., AND DESREUX, V.: Compt. rend. **203**, 733 (1936).  
(77) DUPONT, G., DULOU, R., DESREUX, V., AND PICOUX, R.: Bull. soc. chim. [5] **5**, 322 (1938).  
(78) DUPONT, G., AND PAQUOT, C.: Compt. rend. **205**, 805 (1937).  
(79) DURLAND, J. R., AND ADKINS, H.: J. Am. Chem. Soc. **59**, 135 (1937).  
(80) DURLAND, J. R., AND ADKINS, H.: J. Am. Chem. Soc. **60**, 1501 (1938).  
(81) DYAKOVA, M. K.: J. Applied Chem. (U. S. S. R.) **4**, 819 (1931); Chem. Abstracts **26**, 1922.  
(82) DYAKOVA, M. K., AND LOZOVOI, A. V.: J. Gen. Chem. (U. S. S. R.) **8**, 105 (1938); Chem. Abstracts **32**, 5287.  
(83) DYAKOVA, M. K., AND LOZOVOI, A. V.: J. Gen. Chem. (U. S. S. R.) **9**, 26 (1939); Chem. Abstracts **33**, 6254.  
(84) ELLIS, C.: *Hydrogenation of Organic Substances*, 3rd edition. D. Van Nostrand Co., New York (1930).  
(85) ESCOURROU, R.: Bull. soc. chim. **43**, 1101 (1928).  
(86) EVANS, J. T., AND FARMER, E. H.: J. Chem. Soc. **1928**, 1644.  
(87) I. G. FARBENINDUSTRIE: French patent 834,111 (1938); Chem. Abstracts **33**, 3393.  
(88) I. G. FARBENINDUSTRIE: French patent 837,196 (1939); Chem. Abstracts **33**, 6872.  
(89) FARKAS, A., AND FARKAS, L.: Trans. Faraday Soc. **33**, 827 (1937).  
(90) FARKAS, A., AND FARKAS, L.: Trans. Faraday Soc. **33**, 837 (1937).  
(91) FARKAS, A.: Trans. Faraday Soc. **35**, 906 (1939).  
(92) FARKAS, A., AND FARKAS, L.: J. Am. Chem. Soc. **60**, 22, (1938).  
(93) FARMER, E. H., AND DUFFIN, W. M.: J. Chem. Soc. **1927**, 402.  
(94) FARMER, E. H., AND GALLEY, R. A. E.: J. Chem. Soc. **1932**, 430.  
(95) FARMER, E. H., AND GALLEY, R. A. E.: Nature **131**, 60 (1933).  
(96) FARMER, E. H., AND GALLEY, R. A. E.: J. Chem. Soc. **1933**, 688.  
(97) FARMER, E. H., AND HUGHES, L. A.: J. Chem. Soc. **1934**, 304.  
(98) FARMER, E. H., AND HUGHES, L. A.: J. Chem. Soc. **1934**, 1929.  
(99) FARMER, E. H., AND HUGHES, L. A.: J. Soc. Chem. Ind. **53**, 131 (1934).  
(100) FAVORSKII, A. E.: Chem. Abstracts **34**, 2783 (1940).  
(101) FAVORSKII, E. E.: Russian patent 43,420 (1935); Chem. Abstracts **31**, 7445.  
(102) FERNELIUS, W. C., AND WATT, G. W.: Chem. Rev. **20**, 219 (1937).  
(103) FIESER, L. F., AND HERSHBERG, E. B.: J. Am. Chem. Soc. **59**, 2502 (1937).  
(104) FIESER, L. F., AND HERSHBERG, E. B.: J. Am. Chem. Soc. **60**, 940 (1938).  
(105) FISCHER, E.: Ann. **386**, 380 (1912).  
(106) FISCHER, E., PETERS, K., AND KOCH, H.: Brennstoff Chem. **10**, 383 (1929); Chem. Abstracts **24**, 4918.  
(107) FISCHER, F. G., AND WIEDMANN, O.: Ann. **522**, 1 (1936).  
(108) FOKIN, S.: Z. Elektrochem. **12**, 749, 795 (1906).  
(109) FORESTI, B.: Gazz. chim. ital. **66**, 455 (1936); Chem. Abstracts **31**, 3768.  
(110) FRIES, K., SCHILLING, K., AND LITTMANN, G.: Ber. **65**, 1494 (1932).  
(111) GILMAN, H.: J. Org. Chem. **1**, 315 (1936).  
(112) GILMAN, H.: J. Am. Chem. Soc. **60**, 2333 (1938).  
(113) GLASSSTONE, S., AND HICKLING, A.: *Electrolytic Oxidation and Reduction*. D. Van Nostrand Co., New York (1936).  
(114) GLASSSTONE, S.: Ind. Chemist **5**, 423 (1929); Chem. Abstracts **24**, 788.  
(115) GOEBEL, H.: Ber. pharm. Ges. **32**, 115 (1922); Chem. Abstracts **16**, 3476.  
(116) GOLDBERG, A. A., AND LINSTAD, R. P.: J. Chem. Soc. **1928**, 2343.

- (117) GOLDBERG, M. W., AND HARDEGGER, E.: *Helv. Chim. Acta* **22**, 1294 (1939).
- (118) GOLOVCHAUSKAYA, A. P.: *J. Gen. Chem. (U. S. S. R.)* **10**, 435 (1940); *Chem. Abstracts* **34**, 7847.
- (119) GOLOVCHAUSKAYA, A. P.: *J. Gen. Chem. (U. S. S. R.)* **11**, 608 (1941); *Chem. Abstracts* **35**, 6931.
- (120) GONZALES, A.: *Anales soc. españ. fis. quim.* **24**, 156 (1926); *Chem. Abstracts* **20**, 2310.
- (121) GOSWAMI, M. N.: *Compt. rend.* **179**, 1269 (1924).
- (122) GRAEBE, C., AND LIEBERMANN, C.: *Ann. (Suppl.)* **7**, 265 (1870).
- (123) GREDY, V.: *Bull. soc. chim.* [5] **2**, 1029 (1935).
- (124) GREENHALGH, R. K., AND POLANYI, M.: *Trans. Faraday Soc.* **35**, 520 (1939).
- (125) GRIGNARD, V.: *Bull. soc. chim.* [4] **43**, 473 (1928).
- (126) GRIGNARD, V., AND TCHÉOUFAKI: *Compt. rend.* **188**, 1531 (1929).
- (127) GUBELMANN, I., AND SPIEGLER, L.: U. S. patent 2,167,067; *Chem. Abstracts* **33**, 8625 (1939).
- (128) GUYOT: *Chimie & industrie*, Special No. **410**, 1928; *Chem. Abstracts* **22**, 4522.
- (129) HILDITCH, T. P., AND VIDYARTHI, N. L.: *Proc. Roy. Soc. (London)* **A122**, 552 (1929).
- (130) HÜCKEL, W., AND BRETSCHNEIDER, H.: *Ann.* **540**, 157 (1939).
- (131) HUGEL, G., AND FRIESS, J.: *Bull. soc. chim.* [4] **49**, 1042 (1931).
- (132) HUGEL, G., AND GIDALY: *Bull. soc. chim.* [4] **51**, 639 (1932).
- (132a) HUNAKUBO, E.: *Ber.* **74**, 832 (1941); *Chem. Abstracts* **35**, 6944.
- (133) HURUKAWA, Z.: *J. Electrochem. Assoc. Japan* **7**, 346 (1939); *Chem. Abstracts* **34**, 6482.
- (134) HURUKAWA, Z., AND NAKAGUTI, K.: *J. Soc. Chem. Ind. Japan* **43**, Suppl. binding 142 (1940); *Chem. Abstracts* **34**, 6482.
- (135) INGOLD, C. .: *J. Chem. Soc.* **1926**, 3084.
- (136) INGOLD, C. K., AND ROGERS, M. A. T.: *J. Chem. Soc.* **1935**, 717.
- (137) INGOLD, C. K., AND SHAH, L. D.: *J. Chem. Soc.* **1933**, 885.
- (138) IONOUE, H.: *J. Chem. Ind. Japan* **24**, 906 (1921); *Chem. Abstracts* **16**, 2320 (1922).
- (139) IPATIEFF, V.: *Catalytic Reactions at High Pressures and Temperatures*. Macmillan Company, New York (1936).
- (140) IPATIEFF, V.: *J. Am. Chem. Soc.* **55**, 3696 (1933).
- (141) IPATIEFF, V., CORSON, B. B., AND KURBATOV, I. D.: *J. Phys. Chem.* **43**, 589 (1939).
- (142) IPATIEFF, V., AND ORLOV: *Compt. rend.* **184**, 751 (1927).
- (143) ISAACS, E., AND WILSON, C. L.: *J. Chem. Soc.* **1936**, 202.
- (144) ISAACS, E., AND WILSON, C. L.: *J. Chem. Soc.* **1936**, 574.
- (145) ISAACS, E., AND WILSON, C. L.: *J. Chem. Soc.* **1936**, 810.
- (146) JEANES, A., AND ADAMS, R.: *J. Am. Chem. Soc.* **59**, 2608 (1937).
- (147) JOHNSON, J. R., AND JOHNSON, O. H.: *J. Am. Chem. Soc.* **62**, 2615 (1940).
- (147a) JOHNSON, J. R.: *J. Am. Chem. Soc.* **63**, 2282 (1941).
- (148) KAILAN, A., AND HARTEL, F.: *Monatsh.* **70**, 329 (1937).
- (149) KARRER, P., HELFENSTEIN, A., AND WIDNER, R.: *Helv. Chim. Acta* **11**, 1201 (1928).
- (150) KARRER, P., YEN, Y., AND REICHSTEIN, I.: *Helv. Chim. Acta* **13**, 1308 (1930).
- (151) KARRER, P., AND MORF, R.: *Helv. Chim. Acta* **14**, 833 (1931).
- (152) KAUFMANN, W. E., AND ADAMS, R.: *J. Am. Chem. Soc.* **45**, 3029 (1923).
- (153) KAZANSKII, B. A., PLATO, A. F., AND GNATENKO, K. M.: *Ber.* **69**, 954 (1936).
- (154) KAZANSKII, B. A., AND GLUSHNEV, N. F.: *J. Gen. Chem. (U. S. S. R.)* **8**, 642 (1938); *Chem. Abstracts* **33**, 1279.
- (155) KAZANSKII, B. A., AND GLUSHNEV, N. F.: *Bull. acad. sci. U. R. S. S., Classe sci. mat. nat., Sér. chim.* **1938**, 1061; *Chem. Abstracts* **33**, 6256.
- (156) KAZANSKII, B. A., AND GLUSHNEV, N. F.: *Bull. acad. sci. U. R. S. S., Classe sci. mat. nat., Sér. chim.* **1938**, 1065; *Chem. Abstracts* **33**, 6233.
- (157) KAZANSKII, B. A., AND SMIRNOVA, N. V.: *Bull. acad. sci. U. R. S. S., Classe sci. mat. nat., Sér. chim.* **1937**, 547; *Chem. Abstracts* **32**, 2090 (1938).

- (158) KAZANSKII, B. A., AND TATEVOSYAN, G. T.: J. Gen. Chem. (U. S. S. R.) **8**, 1428 (1938); Chem. Abstracts **33**, 4204.
- (159) KAZANSKII, B. A., AND TATEVOSYAN, G. T.: J. Gen. Chem. (U. S. S. R.) **9**, 1458 (1939); Chem. Abstracts **34**, 2783.
- (160) KAZANSKII, B. A., AND TATEVOSYAN, G. T.: J. Gen. Chem. (U. S. S. R.) **9**, 2256 (1939); Chem. Abstracts **34**, 4731.
- (161) KELBER, C., AND SCHWARTZ, A.: Ber. **45**, 1946 (1912).
- (162) KERN, J. W., SHRINER, R. L., AND ADAMS, R.: J. Am. Chem. Soc. **47**, 1147 (1925).
- (163) KHARASCH, M. S., WALLING, C., AND MAYO, F. R.: J. Am. Chem. Soc. **61**, 1559 (1939).
- (164) KINDLER, K., AND PESCHKE, W.: Ann. **497**, 193 (1932).
- (165) KLAGES, A.: (a) Ber. **35**, 2633 (1902); (b) Ber. **35**, 2646 (1902); (c) Ber. **35**, 2649 (1902); (d) Ber. **35**, 3506 (1902).
- (166) KLAGES, A.: Ber. **36**, 1632 (1903).
- (167) KLAGES, A.: (a) Ber. **37**, 924 (1904); (b) Ber. **37**, 1447 (1904).
- (168) KLAGES, A.: (a) Ber. **37**, 1721 (1904); (b) Ber. **37**, 2301 (1904).
- (169) KOELSCH, C. F., AND ROSENWALD, R. H.: J. Am. Chem. Soc. **59**, 2170 (1937).
- (170) KOHLER, E. P., AND THOMPSON, R. B.: J. Am. Chem. Soc. **59**, 887 (1937).
- (170a) KOHLER, E. P., AND THOMPSON, R. B.: J. Am. Chem. Soc. **59**, 890 (1937).
- (171) KOMATSU, S., SUGINO, K., AND HAGIWARA, M.: Proc. Imp. Acad. (Tokyo) **6**, 194 (1930); Chem. Abstracts **24**, 4271.
- (171a) KOMORI, S.: J. Soc. Chem. Ind. Japan **43**, Suppl. binding 428 (1940); Chem. Abstracts **35**, 4345.
- (172) KUHN, R., AND BROCKMANN, H.: Ber. **66**, 828 (1933).
- (173) KUHN, R., AND DEUTSCH, A.: Ber. **65**, 817 (1932).
- (174) KUHN, R., AND HOFFER, M.: Ber. **65**, 170 (1932).
- (175) KUHN, R., AND HOFFER, M.: Ber. **66**, 1263 (1933).
- (176) KUHN, R., AND WALLENFELS, K.: Ber. **71**, 783 (1938).
- (177) KUHN, R., AND WINTERSTEIN, A.: Helv. Chim. Acta **11**, 123 (1928).
- (178) KUHN, R., AND WINTERSTEIN, A.: Helv. Chim. Acta **12**, 493 (1929).
- (179) LAGEREV, S. P., AND ABRAMOV, M. M.: J. Gen. Chem. (U. S. S. R.) **8**, 1682 (1938); Chem. Abstracts **33**, 4957 (1939).
- (180) LAGEREV, S. P., AND BABAK, S. F.: J. Gen. Chem. (U. S. S. R.) **7**, 1661 (1937); Chem. Abstracts **31**, 8342.
- (181) LAI, T. Y.: Bull. soc. chim. [4] **53**, 1533 (1933).
- (182) LAW, H. D.: J. Chem. Soc. **101**, 1016 (1912).
- (183) LEBEAU, P., AND PICON, M.: Compt. rend. **158**, 1514 (1914).
- (184) LEBEAU, P., AND PICON, M.: Compt. rend. **159**, 70 (1915).
- (185) LEBEAU, P., AND PICON, M.: Compt. rend. **157**, 137 (1913).
- (185a) LEBEAU, P., AND PICON, M.: Compt. rend. **157**, 223 (1913).
- (186) LEBEDEV, S. V., KOBLIANSKY, G. G., AND YAKUBCHIK, A. O.: J. Chem. Soc. **127**, 417 (1925).
- (187) LEBEDEV, S. V., AND PLATONOV, M.: J. Chem. Soc. **1930**, 321.
- (188) LEBEDEV, S. V., AND STERN, V. Y.: J. Gen. Chem. (U. S. S. R.) **2**, 249 (1932); Chem. Abstracts **27**, 266.
- (189) LEBEDEV, S. V., AND YAKUBCHIK, A. O.: J. Chem. Soc. **1928**, 823.
- (190) LEBEDEV, S. V., AND YAKUBCHIK, A. O.: J. Chem. Soc. **1928**, 2190.
- (191) LEBEDEV, S. V., AND YAKUBCHIK, A. O.: J. Chem. Soc. **1929**, 220.
- (192) LEBEDEV, S. V., GULYAeva, A. I., AND VASILEV, A. A.: J. Gen. Chem. (U. S. S. R.) **5**, 1421 (1935); Chem. Abstracts **30**, 2169.
- (193) LEVY, G.: Ann. chim. [11] **9**, 5-87 (1938).
- (194) LIEBERMANN, C., AND SPIEGEL, L.: Ber. **22**, 779 (1889).
- (195) LIMPRICHT, H.: Ann. **145**, 334 (1868).
- (196) LINNEMANN, E.: Ber. **7**, 856 (1874).
- (197) LOCQUIN, R., AND SUNG, WOUSENG: Compt. rend. **174**, 1551 (1922).

- (198) LOHAUS, H.: J. prakt. Chem. **119**, 235 (1928).
- (199) LOZOVOI, A. V., AND DYAKOVA, M. K.: J. Gen. Chem. (U. S. S. R.) **9**, 895 (1939); Chem. Abstracts **34**, 388.
- (200) LOZOVOI, A. V., AND DYAKOVA, M. K.: J. Gen. Chem. (U. S. S. R.) **10**, 1 (1940); Chem. Abstracts **34**, 4728.
- (200a) LOZOVOI, A. V.: J. Gen. Chem. (U. S. S. R.) **10**, 1855 (1940); Chem. Abstracts **35**, 4358.
- (201) LUCAS, L.: Ber. **21**, 2510 (1888).
- (202) LUTZ, R. E.: J. Am. Chem. Soc. **51**, 3008 (1929).
- (203) LUTZ, R. E., AND REVELEY, W. G.: J. Am. Chem. Soc. **61**, 1854 (1939).
- (204) MAILLARD, A.: Compt. rend. **197**, 1422 (1933).
- (205) MAILLARD, A.: Compt. rend. **200**, 1856 (1935).
- (206) MARGOLIS, E. I.: Ber. **69**, 1710 (1936).
- (207) MARSHALK, C., AND NICOLAJEWSKY, F.: Ber. **43**, 1701 (1910).
- (208) MARTIN, E., AND HUGEL, G.: Bull. soc. chim. [4] **53**, 1500 (1933).
- (209) MAYER, F., AND SCHULTE, T.: Ber. **55**, 2164 (1922).
- (210) METTLER, C.: Ber. **39**, 2933 (1906).
- (211) MICHAELIS, L., AND SCHUBERT, M. P.: Chem. Rev. **22**, 437 (1938).
- (212) MIDGLEY, T., AND HENNE, A. L.: J. Am. Chem. Soc. **51**, 1293 (1929).
- (213) MIDGLEY, T., AND HENNE, A. L.: J. Am. Chem. Soc. **51**, 1294 (1929).
- (214) MILLER, H. F., AND BACHMAN, G. B.: J. Am. Chem. Soc. **57**, 768 (1935).
- (215) MOISSAN, H.: Compt. rend. **127**, 911 (1898).
- (216) MOISSAN, H.: Compt. rend. **136**, 1217 (1903).
- (217) MONBLANOVA, V. V., KOBOSEV, N. I., AND FILIPPOVICH, P.: Acta Physicochim. U. R. S. S. **11**, 317 (1939); Chem. Abstracts **34**, 3186.
- (218) MONBLANOVA, V. V., *et al.*: J. Phys. Chem. (U. S. S. R.) **13**, 326 (1939); Chem. Abstracts **34**, 1256.
- (219) MORRIS, V. N., AND REYERSON, L. H.: J. Phys. Chem. **31**, 1332 (1927).
- (219a) MOZINGO, R.: *Organic Syntheses*, Vol. 21, p. 15. John Wiley and Sons, Inc., New York (1941).
- (220) MUSAEV, I. A., AND GALPERU, G. D.: J. Applied Chem. (U. S. S. R.) **12**, 572 (1939); Chem. Abstracts **33**, 8563.
- (221) MUSKAT, I. E., AND KNAPP, B. H.: Ber. **64**, 779 (1931).
- (222) MUSKAT, I. E., AND KNAPP, B. H.: J. Am. Chem. Soc. **56**, 943 (1934).
- (223) MUSSER, D. M., AND ADKINS, H.: J. Am. Chem. Soc. **60**, 664 (1938).
- (224) NIKOLAEVA, A. F., AND PUCHKOV, P. V.: Bull. acad. sci. U. R. S. S., Classe sci. math. nat., Sér. chim. **1938**, 913. Chem. Abstracts **33**, 5815.
- (225) OGAWA, T., AND YOKOTA, T.: Bull. Chem. Soc. Japan **5**, 266 (1930); Chem. Abstracts **25**, 281.
- (226) OTT, E., BARTH, V., AND GLIMSER, O.: Ber. **67**, 1669 (1934).
- (227) OTT, E., BEHR, B., AND SCHROETER, R.: Ber. **61**, 2124 (1928).
- (228) OTT, E., AND SCHROETER, R.: Ber. **60**, 624 (1927).
- (229) OTT, E., AND SCHURMANN, F.: Ber. **61**, 2119 (1928).
- (230) PAAL, C.: Ber. **42**, 3930 (1909).
- (231) PAAL, C.: Ber. **45**, 2221 (1912).
- (232) PAAL, C., AND HARTMAN, W.: Ber. **43**, 248 (1910).
- (233) PAAL, C., AND SCHIEDEWITZ, H.: Ber. **60**, 1221 (1927).
- (234) PAAL, C., AND SCHIEDEWITZ, H.: Ber. **63**, 766 (1930).
- (235) PAAL, C., SCHIEDEWITZ, H., AND RAUSCHER, K.: Ber. **64**, 1521 (1931).
- (236) PAAL, C., AND SCHWARTZ, A.: Ber. **48**, 1202 (1915).
- (237) PALFRAY, L.: Compt. rend. **206**, 1976 (1938).
- (238) PAUL, R., AND HILLY, G.: Compt. rend. **206**, 608 (1938).
- (239) PETROV, A. D., AND ANTZUS, L. I.: Compt. rend. acad. sci. U. R. S. S. **4**, 295 (1934); Chem. Abstracts **29**, 2906.



- (240) PICHLER, H.: Ges. Abhandl. Kenntnis Kohle **11**, 395 (1934); Chem. Abstracts **29**, 6567.
- (241) PLATONOV, M. S.: J. Russ. Phys-Chem. Soc. **61**, 1055 (1929); Chem. Abstracts **24**, 539.
- (242) POMILIO, U.: Z. Elektrochem. **21**, 444 (1915).
- (243) PRINS, H. J.: Rec. trav. chim. **42**, 473 (1923).
- (244) PRINS, H. J.: Rec. trav. chim. **44**, 1093 (1925).
- (245) PROKOPETS, E. I.: J. Applied Chem. (U. S. S. R.) **7**, 159 (1934); Chem. Abstracts **28**, 7480.
- (246) PROKOPETS, E. I., AND ERU, I. I.: Chem. Abstracts **29**, 1961 (1935).
- (247) PROKOPETS, E. I., GAVRILOVA, G. E., AND KLIMOVA, L. A.: J. Applied Chem. (U. S. S. R.) **11**, 823 (1938); Chem. Abstracts **33**, 1717 (1939).
- (248) PROKOPETS, E. I.: J. Applied Chem. (U. S. S. R.) **11**, 835 (1938); Chem. Abstracts **33**, 1718.
- (249) PROKOPETS, E. I., *et al.*: J. Applied Chem. (U. S. S. R.) **11**, 1631 (1939); Chem. Abstracts **33**, 5817.
- (250) PUCHKOV, P. V.: J. Gen. Chem. (U. S. S. R.) **8**, 1756 (1938); Chem. Abstracts **33**, 4968.
- (251) PUMMERER, R., AND BINAPFL, J.: Ber. **54**, 2768 (1921).
- (252) RAPOPORT, I. B., AND SILCHENKO, E. I.: J. Applied Chem. (U. S. S. R.) **10**, 1427 (1937); Chem. Abstracts **32**, 1688.
- (253) VON RISSEGHEN, H.: Bull. soc. chim. Belg. **47**, 261 (1938).
- (254) ROSS, W. H., CULBERTSON, J. B., AND PARSONS, J. P.: J. Ind. Eng. Chem. **13**, 775 (1921).
- (255) ROWE, F. M.: J. Soc. Chem. Ind. **39**, 240T (1920).
- (256) RUGGLI, P., AND ZAESLIN, H.: Helv. Chim. Acta **18**, 853 (1935).
- (257) RUPE, H., *et al.*: Ann. **369**, 339 (1909).
- (258) RUPE, H., AND LOTZ, W.: Ber. **36**, 15 (1903).
- (258a) RUZICKA, L.: Helv. Chim. Acta **2**, 184 (1911).
- (259) SABATIER, P., AND SENDERENS, J. B.: Compt. rend. **128**, 1173 (1899).
- (260) SABATIER, P., AND SENDERENS, J. B.: Compt. rend. **131**, 40 (1900).
- (261) SABATIER, P., AND SENDERENS, J. B.: Compt. rend. **132**, 1254 (1901).
- (262) SADIKOV, W. S., AND MICHAÏLOV, A. K.: Ber. **61**, 1792 (1928).
- (263) SAUER, J., AND ADKINS, H.: J. Am. Chem. Soc. **59**, 1 (1937).
- (264) SCHLENK, W., APPENRODT, J., MICHAEL, A., AND THAL, A.: Ber. **47**, 473 (1914).
- (265) SCHLENK, W., AND BERGMANN, E.: Ann. **463**, 1 (1928).
- (265a) SCHLENK, W., AND BERGMANN, E.: Ann. **463**, 98 (1928).
- (266) SCHLENK, W., AND BERGMANN, E.: Ann. **479**, 42 (1930).
- (267) SCHLENK, W., AND BERGMANN, E.: Ann. **479**, 58 (1930).
- (268) SCHLENK, W., AND BERGMANN, E.: Ann. **479**, 78 (1930).
- (269) SCHLUBACH, H.: Ber. **48**, 13 (1913).
- (270) SCHMIDT, O.: Chem. Rev. **12**, 363 (1933).
- (271) SCHMIDT, O.: Z. physik. Chem. **A176**, 237 (1936).
- (272) SCHOOREL, G. F., TULLENERS, A. J., AND WATERMAN, H. I.: J. Inst. Petroleum Tech. **18**, 179 (1932); Chem. Abstracts **27**, 961.
- (273) SCHROETER, G.: Ber. **57**, 2003 (1924).
- (274) SCHROETER, G., MULLER, H., AND HUANG, J.: Ber. **62**, 645 (1929).
- (274a) SCHROETER, G.: Angew. Chem. **54**, 229, 252 (1941); Chem. Abstracts **35**, 6241.
- (275) SCHUSTER, C.: Z. Elektrochem. **38**, 614 (1932).
- (276) SCOTT, N. D., HANSLEY, V. L., AND WALKER, J. F.: U. S. patents 2,171,867, 2,171,868, 2,171,869 (1939); Chem. Abstracts **34**, 115-16.
- (277) SCOTT, N. D.: U. S. patent 2,183,847 (1939); Chem. Abstracts **34**, 2394.
- (278) SCOTT, N. D., WALKER, J. F., AND HANSLEY, V. L.: J. Am. Chem. Soc. **58**, 2442 (1936).
- (279) SEMMLER, F. W.: Ber. **34**, 3122 (1901).
- (280) SHERRILL, M. L., AND MATLACK, E. S.: J. Am. Chem. Soc. **59**, 2134 (1937).

- (281) SIEGLITZ, A., AND JASSOY, H.: Ber. **54**, 2133 (1921).  
(282) SIOMI, K., AND IWAMOTO, T.: J. Soc. Chem. Ind. Japan **41**, Suppl. binding 401 (1938); Chem. Abstracts **33**, 3328.  
(283) SKITA, A.: Ann. **431**, 1 (1922).  
(284) SKITA, A.: Ber. **55**, 139 (1922).  
(285) SKITA, A.: Ber. **55**, 144 (1922).  
(286) SKITA, A.: Ber. **57**, 1977 (1924).  
(287) SKITA, A., AND MEYER, W. A.: Ber. **45**, 3579 (1912).  
(288) SMITH, L. I., AND HOEHN, H. H.: J. Am. Chem. Soc. **63**, 1184 (1941).  
(289) SPERENSKI, N.: Chem. Zentr. **1899**, II, 181.  
(290) STOBBE, H.: Ber. **37**, 2662 (1904).  
(291) STRAUS, F.: Ann. **342**, 190 (1905).  
(292) STRAUS, F., AND GRINDEL, H.: Ann. **439**, 276 (1924).  
(293) SUNG, WOUSENG: Ann. chim. [10] **1**, 372 (1924).  
(294) SWANN, S.: Trans. Electrochem. Soc. **77**, 459 (1940).  
(295) TAFEL, J.: Ber. **33**, 2209 (1900).  
(296) THIELE, J.: Ann. **306**, 87 (1899).  
(297) THIELE, J.: Ber. **35**, 2320 (1902).  
(298) THIELE, J., AND BUHNER, A.: Ann. **347**, 249 (1906).  
(299) THIELE, J., AND HENLE, F.: Ann. **347**, 294 (1906).  
(299a) THIELE, J., AND HENLE, H.: Ann. **348**, 1 (1906).  
(300) THIELE, J., AND MERCK, K.: Ann. **415**, 257 (1915).  
(301) THOMPSON, G.: J. Am. Chem. Soc. **56**, 2744 (1934).  
(302) THOMPSON, A. F., AND WYATT, S. B.: J. Am. Chem. Soc. **62**, 2555 (1940).  
(303) TRAUBE, W., AND PASSARGE, W.: Ber. **49**, 1692 (1916).  
(304) TRUFFAULT, R.: Bull. soc. chim. [5] **1**, 206 (1934).  
(305) TRUFFAULT, R.: Bull. soc. chim. [5] **1**, 391 (1934).  
(306) TULEY, W. F., AND ADAMS, R.: J. Am. Chem. Soc. **47**, 3061 (1925).  
(307) VALEUR, A.: Bull. soc. chim. [3] **29**, 687 (1903).  
(308) VAUGHEN, J. V., AND LAZIER, W. A.: J. Am. Chem. Soc. **53**, 3719 (1931).  
(309) VAVON, G.: Bull. soc. chim. [4] **41**, 1253 (1927).  
(310) VAVON, G.: Bull. soc. chim. [4] **49**, 985 (1931).  
(311) VAVON, G., AND ANZIANI, P.: Bull. soc. chim. [4] **41**, 1638 (1927).  
(312) VAVON, G., AND BERTON, A. L.: Bull. soc. chim. [4] **37**, 296 (1925).  
(313) VAVON, G., AND CALLIER, A.: Bull. soc. chim. [4] **41**, 677 (1927).  
(314) VAVON, G., AND DETRIE: Compt. rend. **172**, 1231 (1921).  
(315) VAVON, G., AND JAKES, M.: Compt. rend. **183**, 299 (1926).  
(316) VAVON, G., AND JAKES, M.: Bull. soc. chim. [4] **41**, 81 (1927).  
(317) VORLÄNDER, D., AND WEINSTEIN, P.: Ber. **56**, 1122 (1923).  
(318) WALKER, J. F., AND SCOTT, N. D.: J. Am. Chem. Soc. **60**, 951 (1938).  
(319) WATERMAN, H. I., CLAUSEN, J. F., AND TULLENERS, A. J.: Rec. trav. chim. **53**, 821 (1934).  
(320) WATERMAN, H. I., LEENDERTSE, J. J., AND CRANENDONK, A. C.: Rec. trav. chim. **58**, 83 (1939).  
(320a) WESSELY, F. V., AND WELLEBA, H.: Ber. **74**, 777 (1941); Chem. Abstracts **35**, 6585.  
(321) WEYGAND, C., AND WERNER, A.: Ber. **71**, 2469 (1938).  
(322) WEYGAND, C., WERNER, A., AND LANZENDORF, W.: J. prakt. Chem. **151**, 231 (1938).  
(323) WIELAND, H.: Ber. **45**, 484 (1912).  
(324) WIELAND, H., AND KLOSS, H.: Ann. **470**, 201 (1929).  
(325) WILLIAMS, D. E., AND JAMES, T. C.: Chem. Abstracts **17**, 3493 (1923).  
(326) WILLIAMS, E. C., AND BEECK, O.: *Twelfth Report of Committee on Catalysis*, pp. 107-119. National Research Council, Washington, D. C. (1940).  
(327) WILLSTÄTTER, R., AND HATT, D.: Ber. **45**, 1471 (1912).  
(328) WILLSTÄTTER, R., SEITZ, F., AND BUMM, E.: Ber. **61**, 871 (1928).

- (329) WILLSTÄTTER, R., AND SEITZ, F.: Ber. **56**, 1388 (1923).  
(330) WILLSTÄTTER, R., AND SEITZ, F.: Ber. **57**, 683 (1924).  
(331) WILLSTÄTTER, R., AND WALDSCHMIDT-LEITZ, E.: Ber. **54**, 113 (1921).  
(332) WILSON, C. L.: Trans. Electrochem. Soc. **75**, 353 (1939).  
(333) WISLICENUS, H.: J. prakt. Chem. **54**, 18 (1896).  
(334) WITTIG, G., AND KLEIN, A.: Ber. **69**, 2087 (1936).  
(335) WITTIG, G.: Ber. **63**, 943 (1930); **64**, 437 (1931).  
(336) WOOSTER, C. B.: U. S. patent 2,182,242 (1939); Chem. Abstracts **34**, 1993.  
(337) WOOSTER, C. B.: Chem. Rev. **11**, 23 (1932).  
(338) WOOSTER, C. B., AND GODFREY, K. L.: J. Am. Chem. Soc. **59**, 596 (1937).  
(339) WOOSTER, C. B., AND RYAN, J. F.: J. Am. Chem. Soc. **56**, 1133 (1934).  
(340) WOOSTER, C. B., AND SMITH, F. B.: J. Am. Chem. Soc. **53**, 179 (1931).  
(340a) WRIGHT, G. F.: J. Am. Chem. Soc. **61**, 2106 (1939).  
(341) WUEST, H. M.: Ann. **415**, 291 (1915).  
(342) YURASHEVSKII, N. K.: J. Gen. Chem. (U. S. S. R.) **5**, 1098 (1935); Chem. Abstracts **30**, 1374.  
(343) YURASHEVSKII, N. K.: J. Gen. Chem. (U. S. S. R.) **8**, 438 (1938); Chem. Abstracts **32**, 7908.  
(344) ZALKIND, Y. S.: J. Russ. Phys-Chem. Soc. **52**, 191 (1920); Chem. Abstracts **17**, 1453.  
(345) ZALKIND, Y. S.: Ber. **60**, 1125 (1927).  
(346) ZALKIND, Y. S., *et al.*: J. Russ. Phys-Chem. Soc. **50**, 19 (1918); Chem. Abstracts, **18**, 1466 (1924).  
(347) ZALKIND, Y. S.: J. Gen. Chem. (U. S. S. R.) **5**, 1768 (1935); Chem. Abstracts **30**, 3408.  
(348) ZALKIND, Y. S., AND BUKHOVETZ, S. V.: J. Gen. Chem. (U. S. S. R.) **7**, 2417 (1937); Chem. Abstracts **32**, 2086.  
(349) ZALKIND, Y. S., AND KHUDEKOVA, N. D.: J. Gen. Chem. (U. S. S. R.) **10**, 521 (1940); Chem. Abstracts **34**, 7847.  
(350) ZALKIND, Y. S., AND MARTINSON, E. E.: J. Gen. Chem. (U. S. S. R.) **6**, 1085 (1936); Chem. Abstracts **31**, 1012 (1937).  
(351) ZALKIND, Y. S., AND MARTINSON, E. E.: J. Gen. Chem. (U. S. S. R.) **7**, 815 (1937); Chem. Abstracts **31**, 5787.  
(352) ZALKIND, Y. S., AND NEDZVETSKII, S. V.: J. Gen. Chem. (U. S. S. R.) **3**, 573 (1933); Chem. Abstracts **28**, 2707.  
(353) ZALKIND, Y. S., AND NOGAIDELI, A. I.: J. Gen. Chem. (U. S. S. R.) **8**, 1382 (1938); Chem. Abstracts **33**, 4195.  
(354) ZALKIND, Y. S., AND SHUVALOV, N. M.: J. Gen. Chem. (U. S. S. R.) **7**, 1235 (1937); Chem. Abstracts **31**, 6206.  
(355) ZALKIND, Y. S., AND SMAGMA, Z. V.: J. Gen. Chem. (U. S. S. R.) **7**, 470 (1937); Chem. Abstracts **31**, 4264.  
(356) ZALKIND, Y. S., VISHNYAKOV, M. N., AND MOREV, L. N.: J. Gen. Chem. (U. S. S. R.) **3**, 91 (1933); Chem. Abstracts **28**, 1669.  
(357) ZARTMAN, W. H., AND ADKINS, H.: J. Am. Chem. Soc. **54**, 1668 (1932).  
(358) ZEISEL, S., AND NEUWIRTH, M.: Ann. **433**, 121 (1923).  
(359) ZELINSKY, N. D., AND TUROVA-POLLAK, M. B.: Ber. **62**, 2865 (1929).  
(360) ZELINSKY, N. D., AND MARGOLIS, E. I.: Ber. **65**, 1613 (1932).  
(361) ZIEGLER, K.: Z. angew. Chem. **49**, 499 (1936).  
(362) ZIEGLER, K., COLONIUS, H., AND SHAFER, O.: Ann. **473**, 36 (1929).  
(363) ZIEGLER, K., HAFNER, F., AND GRIMM, H.: Ann. **528**, 101 (1937).  
(364) ZIEGLER, K., JAKOB, L., WOLLTHAN, H., AND WENZ, A.: Ann. **511**, 64 (1934).  
(365) ZIEGLER, K., AND SCHAFER, O.: Ann. **479**, 150 (1930).  
(366) ZONIS, S.: J. Gen. Chem. (U. S. S. R.) **9**, 2191 (1939); Chem. Abstracts **34**, 4052.